

TECHNICAL CATALOGUE

MONO SPLIT

RAF-25RXE
RAF-35RXE
RAF-50RXE



RAC-25FXE
RAC-35FXE

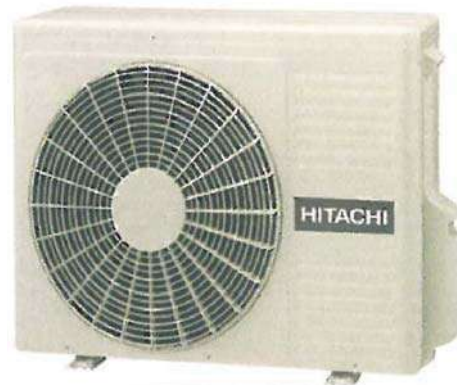

RAC-50FXE



HITACHI

Specifications in this catalogue are subject to change without prior notice in order for HITACHI to bring in the latest innovations to their customers

Whilst every effort is made to ensure that all dimensions and specifications are correct, any printers' error not rectified are outside the control of HITACHI, who cannot be held responsible for the same

CONTENTS

CONTENTS	1
1 SPECIFICATIONS	3
1.1. FLOOR TYPE (RAF-25RXE/35RXE/50RXE)	3
1.2. FLOOR TYPE (RAC-25FXE/35FXE/50FXE)	4
2 DIMENSIONAL DATA	5
2.1. FLOOR TYPE: RAF-25RXE/35RXE/50RXE	5
2.2. FLOOR TYPE: RAC-25FXE/35FXE	6
2.3. FLOOR TYPE: RAC-50FXE	7
3 CAPACITIES TABLE	8
3.1. CAPACITY CHARACTERISTIC CURVES	8
3.1.1. RAF-25RXE/RAC-25FXE	8
3.1.2. RAF-35RXE/RAC-35FXE	8
3.1.3. RAF-50RXE/RAC-50FXE	9
3.2. CORRECTION FACTORS ACCORDING TO PIPING LENGTH	10
3.3. CORRECTION FACTORS ACCORDING TO DEFROSTING OPERATION	12
4 SOUND DATA	13
4.1. RAC-25FXE	13
4.2. RAC-35FXE	14
4.3. RAC-50FXE	15
5 WORKING RANGE	16
5.1. POWER SUPPLY	16
5.2. WORKING RANGE	16
6 ELECTRICAL DATA	17
6.1. INDOOR UNIT	17
6.2. OUTDOOR UNIT	17
7 WIRING DIAGRAM	18
7.1. RAF-25RXE, RAF-35RXE, RAF-50RXE	18
7.2. RAC-25FXE, RAC-35FXE	19
7.3. RAC-50FXE	20
8 REFRIGERANT CYCLE	21
8.1. FLOOR TYPE: RAF-25RXE/RAC-25FXE, RAF-35RXE/RAC-35FXE	21
8.2. FLOOR TYPE: RAF-50RXE / RAC-50FXE	22
9 CONTROL AND FUNCTION	23
9.1. WIRELESS REMOTE CONTROL FUNCTION	23
9.2. AUTO CHANGEOVER	24
9.3. SHIFT VALUE	24
9.4. OPERATION LOCK	25
9.5. SETTING THE PREVENTION OF MUTUAL INTERFERENCE	25
9.6. INTERMITTENT FAN SPEED SETTING	26
9.7. FAN SPEED SETTING IN THERMO OFF IN COOLING	27
9.8. ERROR CODE INFORMATION	28
9.9. ADDITIONAL FUNCTION VIA DIP-SWITCH SETTINGS	29
9.9.1. AUTO RESTART FUNCTION	29
9.9.2. HEATING/COOLING ONLY MODEL SELECTION	29

10	OPTION LIST	30
10.1.	WIRED REMOTE CONTROL – SPX-RCDB	30
10.1.1.	SHIFT VALUE	30
10.1.2.	ERROR CODE INFORMATION	31
10.2.	H-LINK ADAPTOR – PSC 6RAD	33
10.2.1.	SAFETY SUMMARY	33
10.2.2.	INSTALLATION WORK	33
10.2.3.	ELECTRICAL WIRING	34
10.2.4.	DIP SWITCH SETTING	35
10.2.5.	TEST RUN	36
10.3.	DRY CONTACT (SPX-WDC3) APPLICATION (USING DIP SWITCH)	37
10.4.	DISTRIBUTOR – SPX-DST1	39
10.5.	DISTRIBUTOR – SPX-RAFGLS	40

1 SPECIFICATIONS

1.1. FLOOR TYPE (RAF-25RXE/35RXE/50RXE)

INDOOR	Unit	RAF-25RXE	RAF-35RXE	RAF-50RXE
Nominal capacity adjustable		no	no	no
Nominal Cooling capacity (min – max)	kW	2.50 (0.90 - 3.10)	3.5 (0.9 - 4.0)	5.0 (0.9 - 5.2)
Cooling sensible capacity	kW	2.5	2.9	3.7
Nominal Heating capacity (min – max)	kW	3.40 (0.90 - 4.40)	4.5 (0.9 - 5.0)	6.0 (0.9 - 8.1)
Noise level cooling (sound pressure) (SL / L / M / H)	dB(A)	20/26/31/38	20/26/31/39	22/29/36/43
Noise level heating (sound pressure) (SL / L / M / H)	dB(A)	20/26/31/38	20/26/31/39	22/29/36/44
Noise level (sound power)	dB(A)	52	53	57
Air flow cooling mode (SL / L / M / H)	m ³ /h	270/390/510/630	270/390/510/660	300/450/540/700
Air flow heating mode (SL / L / M / H)	m ³ /h	300/420/540/660	300/420/540/690	330/480/570/730
Fan Motor	W	38	38	38
Dehumidification	l/h	1.4	1.9	2.8
Dimensions (H x W x D)	mm	590 x 750 x 215	590 x 750 x 215	590 x 750 x 215
Weight	kg	15	15	15
Condensate Drain	mm	φ16	φ16	φ16
Running current (C/H)	A	5.13 / 4.87	6.00 / 5.87	9.13 / 11.74
Power supply		230V / 1Ph / 50Hz	230V / 1Ph / 50Hz	230V / 1Ph / 50Hz
Cable section (Interconnection)	mm ²	1.50 x 3 + EARTH	1.50 x 3 + EARTH	2.50 x 3 + EARTH
Piping diameter (Liq / Gas)	Inch	1/4" / 3/8"	1/4" / 3/8"	1/4" / 1/2"
Drain diameter (ext)	mm	φ16	φ16	φ16
Remote control (standard/optional)		RAR-6NE4/ SPX-RCDB	RAR-6N4E/ SPX-RCDB	RAR 6NE4/ SPX-RCDB
Filter				
ACL Filter		-	-	-
ACL part name		-	-	-
Pre-filter (Standard / Optional)		Stainless/-	Stainless/-	Stainless/-

NOTE:

1. The nominal cooling and heating capacity is the combined capacity of the HITACHI standard split system, and are based on the ISO 5151.

Operation Conditions		Cooling	Heating
Indoor Air Inlet Temperature	dB	27.0 °C	20.0 °C
	WB	19.0 °C	15.0 °C
Outdoor Air Inlet Temperature	dB	35.0 °C	7.0 °C
	WB	24.0 °C	6.0 °C
Piping Length: 5.0 meters; Piping Lift: 0 meter dB: Dry Bulb; WB: Wet Bulb			

2. The Sound Pressure Level is based on the following conditions:

- Half height of the unit
- 1 meter from Discharge grille

The above data was measured in an anechoic chamber. Please take into consideration reflected sound of your specific site

1.2. FLOOR TYPE (RAC-25FXE/35FXE/50FXE)

OUTDOOR	UNIT	RAC-25FXE	RAC-35FXE	RAC-50FXE	
Nominal Cooling capacity (min - max)	kW	2.50 (0.90 - 3.10)	3.5 (0.9 - 4.0)	5.0 (0.9 - 5.2)	
Nominal Heating capacity (min - max)	kW	3.40 (0.90 - 4.40)	4.5 (0.9 - 5.0)	6.0 (0.9 - 8.1)	
Nominal cooling power input (min - max)	kW	0.538 (0.155 -1.180)	0.933 (0.155 -1.380)	1.389 (0.500 - 2.100)	
Nominal heating power input (min - max)	kW	0.256 (0.115 -1.120)	1.154 (0.115 -1.350)	1.579 (0.500 - 2.700)	
EER / COP		4.65/4.50	3.75/3.90	3.60/3.80	
SEER / SCOP		15.86/15.34	12.80/13.30	12.28/12.96	
Energy class (SEER/SCOP)		A+++/A++	A++/A++	A++/A+	
Noise level cooling (sound pressure)	dB(A)	45	47	51	
Noise level heating (sound pressure)	dB(A)	47	49	53	
Noise level (sound power)	dB(A)	59	61	65	
Air flow (Cooling / Heating)	m ³ /h	1860/1620	1920/1620	2160 / 2160	
Dimensions (H x W x D)	mm	600 x 792 x 299	600 x 792 x 299	736 x 800 x 350	
Weight	kg	37.5	37.5	51	
Colour		Beige (5Y7/2)	Beige (5Y7/2)	Beige (5Y7/2)	
Power supply		230V / 1Ph / 50Hz	230V / 1Ph / 50Hz	230V / 1Ph / 50Hz	
Recommended fuse size	A	15	15	25	
Starting current (C/H)	A	2.87 / 3.50	4.27 / 5.26	6.33 / 7.19	
Running current (C/H)	A	5.13 / 4.87	6.00 / 5.87	9.13 / 11.74	
Cable section (Power)	mm ²	1.50 x 2 + EARTH	1.50 x 2 + EARTH	2.50 x 2 + EARTH	
Cable section (Interconnection)	mm ²	1.50 x 3 + EARTH	1.50 x 3 + EARTH	2.50 x 3 + EARTH	
Piping diameter (Liq / Gas)	Inch	1/4" / 3/8"	1/4" / 3/8"	1/4" / 1/2"	
Minimum piping length	m	3	3	3	
Maximum piping length / height difference	m	20 / 10	20 / 10	30 / 10	
Current quantity of refrigerant / Chargeless	kg	0.980	0.980	1.200	
Chargeless / Additional refrigerant charge	m / g/m	20/-	20/-	30/-	
Working range (cooling / heating)	°C	-10 ~ 43 / -15 ~ 21	-10 ~ 43 / -15 ~ 21	-10 ~ 43 / -15 ~ 21	
Refrigerant		R32	R32	R32	
Condenser Fan		Propeller Fan			
Compressor	Type		Rotary	Rotary	Rotary
	Oil Type		ACS-68R or equivalent	ACS-68R or equivalent	ACS-68R or equivalent
	Oil Charge	ml	320 ± 20	320 ± 20	440 ± 20
	Coil Resistance	Ω	1.354 at 20°C	1.354 at 20°C	1.354 at 20°C
	Quantity		1	1	1

NOTE:

- The Sound Pressure Level is based on the following conditions:
 - 1 meter from the unit front surface and 1 meter from floor level

The above data was measured in an anechoic chamber. Please take into consideration reflected sound of your specific site

2 DIMENSIONAL DATA

2.1. FLOOR TYPE: RAF-25RXE/35RXE/50RXE

Unit: mm

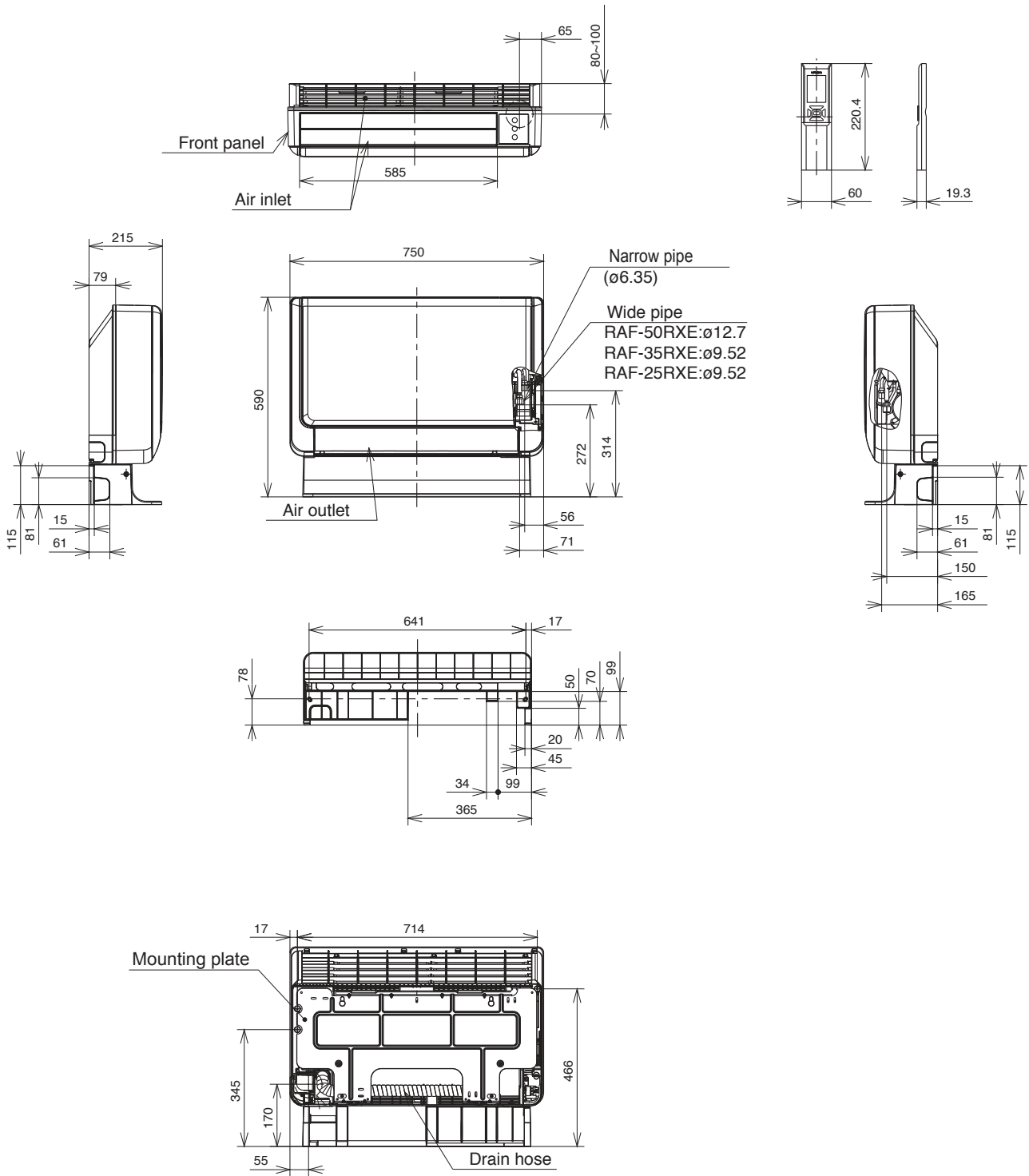

2.2. FLOOR TYPE: RAC-25FXE/35FXE

Unit : mm

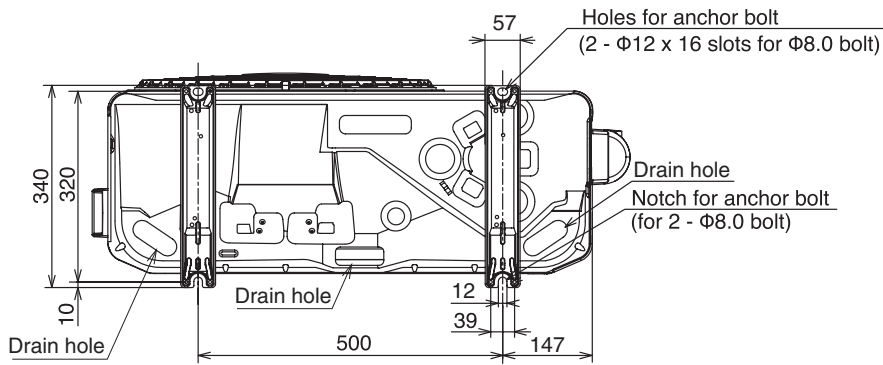
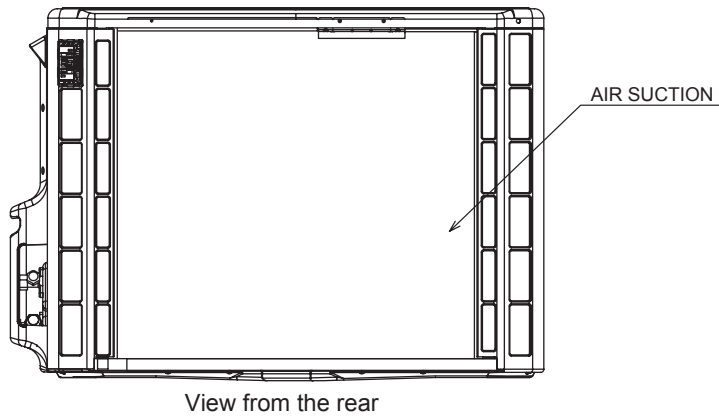
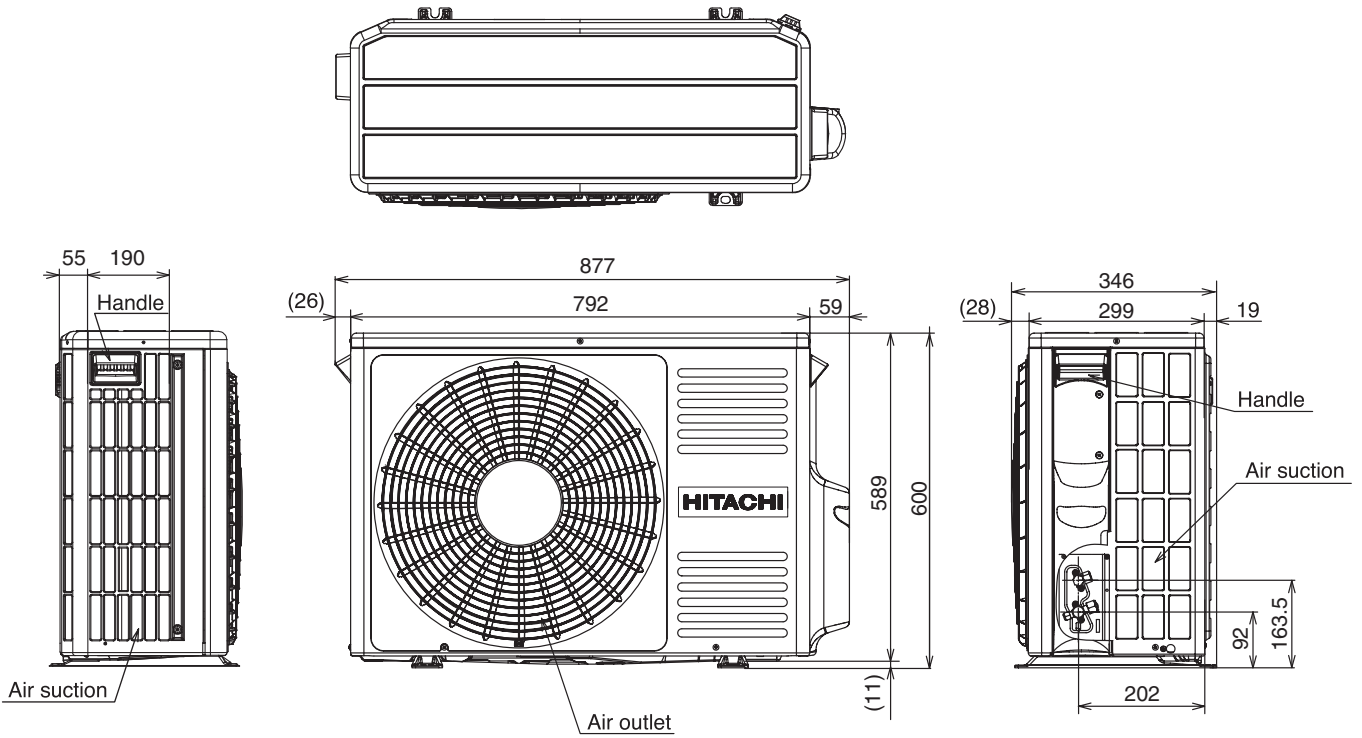

2.3. FLOOR TYPE: RAC-50FXE

Unit : mm

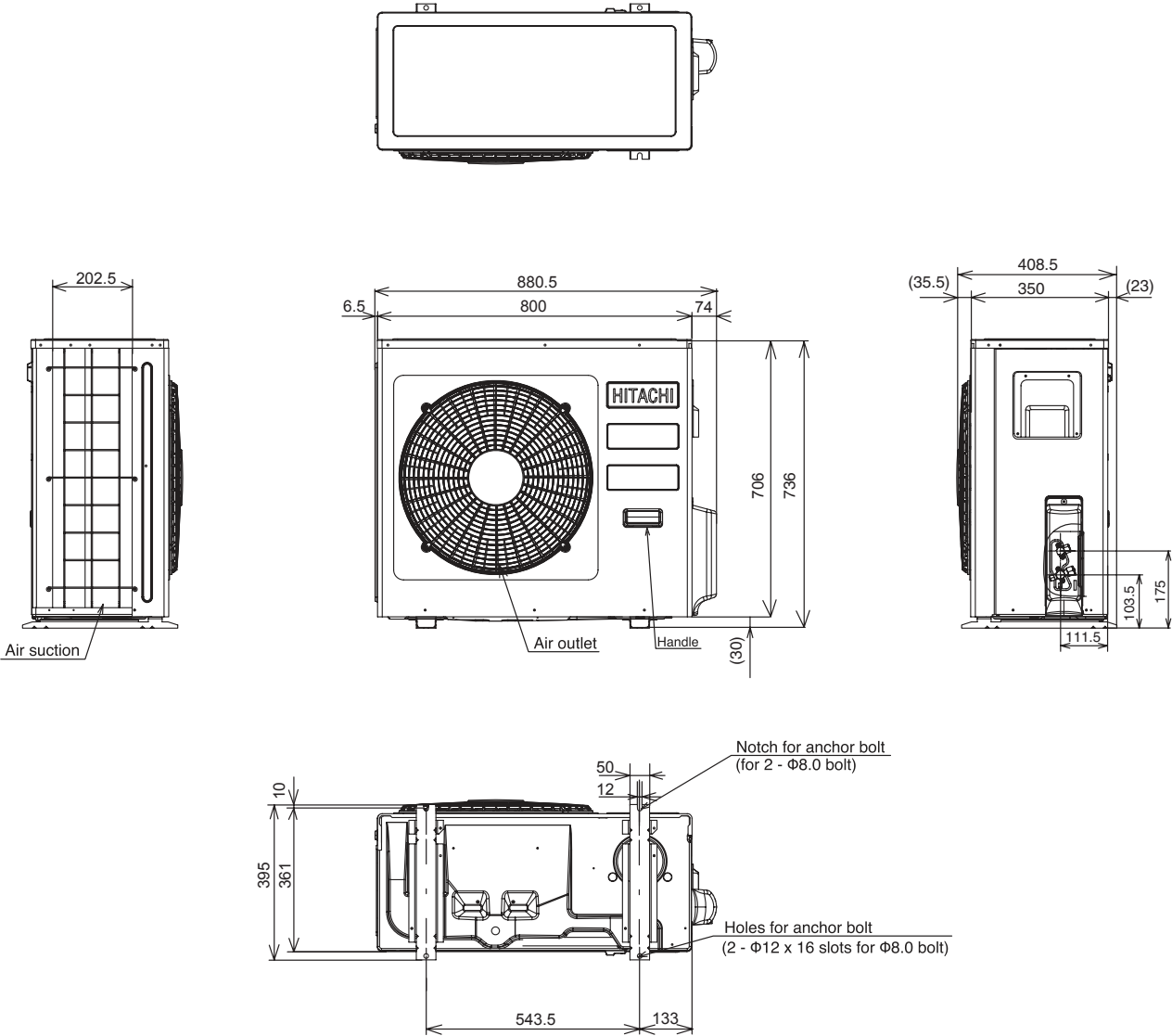

3 CAPACITIES TABLE

3.1. CAPACITY CHARACTERISTIC CURVES

The following charts show the characteristics of outdoor unit capacity, which corresponds with the operating ambient temperature of outdoor unit.

Condition:

① Pipe length / height difference : 5m / 0m

③ Capacity loss due to white frost and defrost operation is not included.

② Indoor fan speed at High mode

3.1.1. RAF-25RXE/RAC-25FXE

COOLING [50Hz, 230V]

INDOOR		OUTDOOR TEMPERATURE (°CDW)																				
EWB	EDB	-10			21			27			32			35			40			43		
°C	°C	TC	SHC	PI	TC	SHC	PI	TC	SHC	PI	TC	SHC	PI	TC	SHC	PI	TC	SHC	PI	TC	SHC	PI
12.0	18	1976	1839	305	2350	2575	380	2175	2377	448	2050	2253	495	1975	2154	516	1850	2030.32	554	1775	1931.28	576
14.0	20	1976	1839	305	2525	2575	380	2350	2402	453	2200	2253	500	2125	2179	522	1975	2030.32	560	1900	1956	586
16.0	22	1976	1957	310	2700	2575	385	2500	2402	459	2350	2253	506	2275	2179	533	2125	2030.32	570	2050	1956	592
18.0	25	2119	2098	314	2875	2798	390	2650	2600	464	2500	2451	511	2400	2352	533	2250	2204	576	2150	2105	597
19.0	27	2190	2169	319	2975	2946	395	2750	2724	469	2600	2575	516	2500	2476	538	2350	2327.44	576	2250	2228.4	597
22.0	30	2428	2146	319	3300	2922	395	3050	2699	469	2875	2550	522	2775	2451	543	2500	2376.96	597	2325	2327.44	629
24.0	32	2595	2146	324	3525	2922	400	3250	2699	475	3075	2550	522	2950	2451	549	2600	2426.48	613	2375	2402	651

HEATING [50Hz, 230V]

INDOOR		OUTDOOR TEMPERATURE (°CDW)																							
EDB		-15			-10			-7			-5			0			7			10			15		
°C		TC	SHC	PI	TC	SHC	PI	TC	SHC	PI	TC	SHC	PI	TC	SHC	PI	TC	SHC	PI	TC	SHC	PI			
16	1224	0	559	1938	0	575	2209	0	599	2390	0	615	2910	0	689	3437	0	698	3750	0	717	4328	0	752	
18	1207	0	567	1921	0	582	2188	0	612	2366	0	631	2880	0	706	3420	0	733	3737	0	748	4311	0	788	
20	1190	0	575	1904	0	590	2169	0	621	2346	0	643	2856	0	718	3400	0	756	3655	0	782	4284	0	824	
22	1173	0	2	1887	0	597	2142	0	634	2312	0	659	2825	0	736	3380	0	786	3696	0	811	4264	0	858	
24	1156	0	590	1870	0	605	2123	0	647	2292	0	675	2802	0	753	3359	0	816	3675	0	842	4202	0	893	

3.1.2. RAF-35RXE/RAC-35FXE

COOLING [50Hz, 230V]

INDOOR		OUTDOOR TEMPERATURE (°CDW)																				
EWB	EDB	-10			21			27			32			35			40			43		
°C	°C	TC	SHC	PI	TC	SHC	PI	TC	SHC	PI	TC	SHC	PI	TC	SHC	PI	TC	SHC	PI	TC	SHC	PI
12.0	18	2766	2276	529	3290	3187	659	3045	2941	777	2870	2788	858	2765	2666	896	2590	2512.48	961	2485	2389.92	998
14.0	20	2766	2276	529	3535	3187	659	3290	2972	786	3080	2788	868	2975	2696	905	2765	2512.48	970	2660	2421	1017
16.0	22	2766	2422	537	3780	3187	668	3500	2972	795	3290	2788	877	3185	2696	924	2975	2512.48	989	2870	2421	1026
18.0	25	2966	2597	545	4025	3462	677	3710	3217	805	3500	3033	886	3360	2911	924	3150	2727	998	3010	2604	1036
19.0	27	3066	2684	554	4165	3646	685	3850	3370	814	3640	3187	896	3500	3064	933	3290	2880.16	998	3150	2757.6	1036
22.0	30	3400	2655	554	4620	3616	685	4270	3340	814	4025	3156	905	3885	3033	942	3500	2941.44	1036	3255	2880.16	1092
24.0	32	3633	2655	562	4935	3616	694	4550	3340	823	4305	3156	905	4130	3033	952	3640	3002.72	1064	3325	2972	1129

EWB : Evaporator Wet Bulb temperature (°C)
 EDB : Evaporator Dry Bulb temperature (°C)
 (°CDB) : Outdoor Unit Inlet Air Dry Temperature (°C)

TC : Total Capacity (W)
 SHC : Sensible Heating Capacity (W)
 PI : Power Input

HEATING [50Hz, 230V]

INDOOR		OUTDOOR TEMPERATURE (°CDW)																							
EDB		-15			-10			-7			-5			0			7			10			15		
°C	TC	SHC	PI	TC	SHC	PI	TC	SHC	PI	TC	SHC	PI	TC	SHC	PI	TC	SHC	PI	TC	SHC	PI	TC	SHC	PI	
16	1620	0	854	2565	0	877	2924	0	914	3164	0	939	3852	0	1051	4550	0	1065	4964	0	1094	5729	0	1148	
18	1598	0	866	2543	0	889	2896	0	934	3132	0	964	3812	0	1078	4527	0	1119	4946	0	1142	5706	0	1202	
20	1575	0	877	2520	0	900	2871	0	949	3105	0	981	3780	0	1096	4500	0	1154	4838	0	1194	5670	0	1258	
22	1553	0	889	2498	0	912	2835	0	968	3060	0	1006	3740	0	1123	4473	0	1200	4892	0	1238	5643	0	1310	
24	1530	0	900	2475	0	923	2810	0	987	3033	0	1031	3708	0	1149	4446	0	1246	4865	0	1286	5562	0	1363	

3.1.3. RAF-50RXE/RAC-50FXE

COOLING [50Hz, 230V]

INDOOR		OUTDOOR TEMPERATURE (°CDW)																							
EWB		-10			21			27			32			35			40			43					
°C	°C	TC	SHC	PI	TC	SHC	PI	TC	SHC	PI	TC	SHC	PI	TC	SHC	PI	TC	SHC	PI	TC	SHC	PI	TC	SHC	PI
12.0	18	3952	2733	787	4700	3826	982	4350	3532	1157	4100	3348	1278	3950	3201	1333	3700	3016.78	1431	3550	2869.62	1486			
14.0	20	3952	2733	787	5050	3826	982	4700	3569	1171	4400	3348	1292	4250	3238	1347	3950	3016.78	1445	3800	2906	1514			
16.0	22	3952	2908	800	5400	3826	995	5000	3569	1184	4700	3348	1306	4550	3238	1375	4250	3016.78	1472	4100	2906	1528			
18.0	25	4237	3118	812	5750	4157	1008	5300	3863	1198	5000	3642	1320	4800	3495	1375	4500	3274	1486	4300	3127	1542			
19.0	27	4380	3223	824	5950	4378	1020	5500	4047	1211	5200	3826	1333	5000	3679	1389	4700	3458.26	1486	4500	3311.1	1542			
22.0	30	4856	3188	824	6600	4341	1020	6100	4010	1211	5750	3789	1347	5550	3642	1403	5000	3531.84	1542	4650	3458.26	1625			
24.0	32	5190	3188	836	7050	4341	1033	6500	4010	1225	6150	3789	1347	5900	3642	1417	5200	3605.42	1583	4750	3569	1681			

HEATING [50Hz, 230V]

INDOOR		OUTDOOR TEMPERATURE (°CDW)																							
EDB		-15			-10			-7			-5			0			7			10			15		
°C	TC	SHC	PI	TC	SHC	PI	TC	SHC	PI	TC	SHC	PI	TC	SHC	PI	TC	SHC	PI	TC	SHC	PI	TC	SHC	PI	
16	2160	0	1168	3420	0	1199	3899	0	1250	4218	0	1284	5136	0	1438	6066	0	1456	6618	0	1496	7638	0	1570	
18	2130	0	1184	3390	0	1215	3861	0	1277	4176	0	1318	5082	0	1474	6036	0	1531	6594	0	1562	7608	0	1644	
20	2100	0	1199	3360	0	1231	3828	0	1297	4140	0	1341	5040	0	1499	6000	0	1578	6450	0	1633	7560	0	1720	
22	2070	0	1215	3330	0	1247	3780	0	1324	4080	0	1376	4986	0	1535	5964	0	1641	6522	0	1693	7524	0	1791	
24	2040	0	1231	3300	0	1262	3747	0	1350	4044	0	1409	4944	0	1572	5928	0	1704	6486	0	1758	7416	0	1864	

EWB : Evaporator Wet Bulb temperature (°C)
 EDB : Evaporator Dry Bulb temperature (°C)
 (°CDB) : Outdoor Unit Inlet Air Dry Temperature (°C)

TC : Total Capacity (W)
 SHC : Sensible Heating Capacity (W)
 PI : Power Input

3.2. CORRECTION FACTORS ACCORDING TO PIPING LENGTH

Correction Factor for **Cooling Capacity** according to Piping Length

The cooling capacity should be corrected according to the following formula:

$$CCA = CC \times F$$

- CCA: Actual Corrected Cooling Capacity (kcal/h)
- CC: Cooling Capacity in the Performance Table (kcal/h)
- F: Correction Factor Based on the Equivalent Piping Length

Correction Factor for **Heating Capacity** according to Piping Length

The heating capacity should be corrected according to the following formula:

$$HCA = HC \times F$$

- HCA: Actual Corrected Heating Capacity (kcal/h)
- HC: Heating Capacity in the Performance Table (kcal/h)
- F: Correction Factor Based on the Equivalent Piping Length

The correction factors are shown in the following figure.

Equivalent Piping Length for:

- One 90° Elbow is 0.5m.
- One 180° Curve is 1.5m.

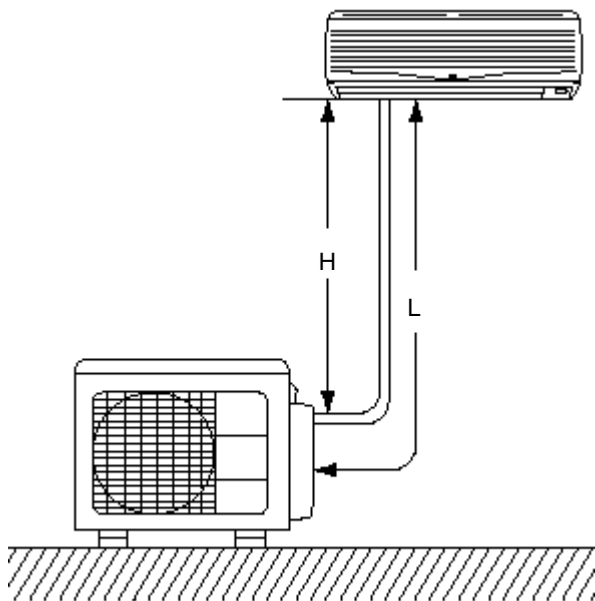

- H: Vertical Distance Between Indoor Unit and Outdoor Units in Meters
- L: Actual One-Way Piping Length Between Indoor Unit and Outdoor Unit in Meters
- EL: Equivalent Total Distance Between Indoor Unit and Outdoor Unit in Meters (Equivalent One-Way Piping Length)

Models : RAF-25RXE/RAC-25FXE

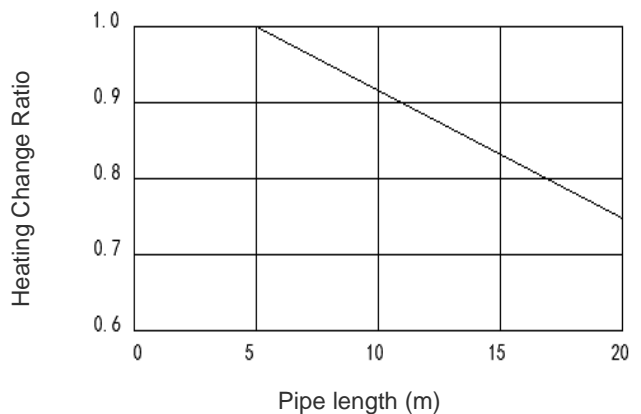
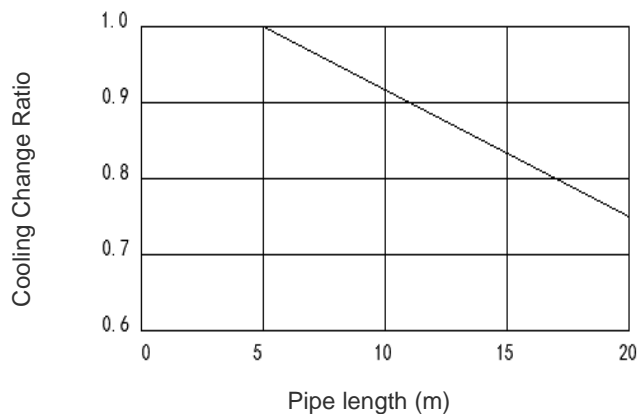

Models : RAF-35RXE/RAC-35FXE

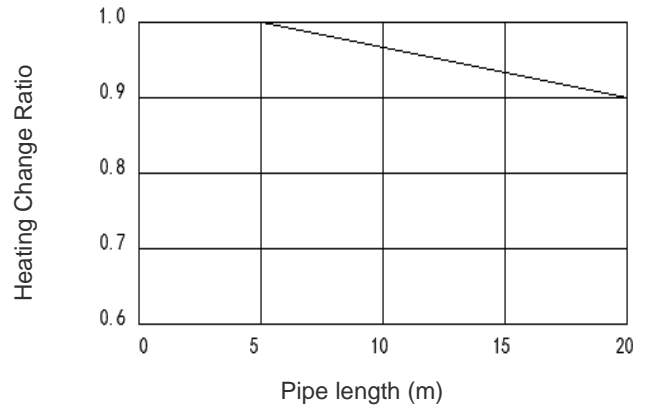
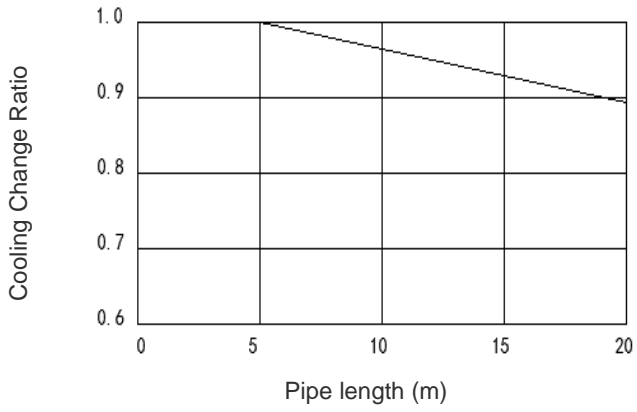

Models : RAF-50RXE/RAC-50FXE

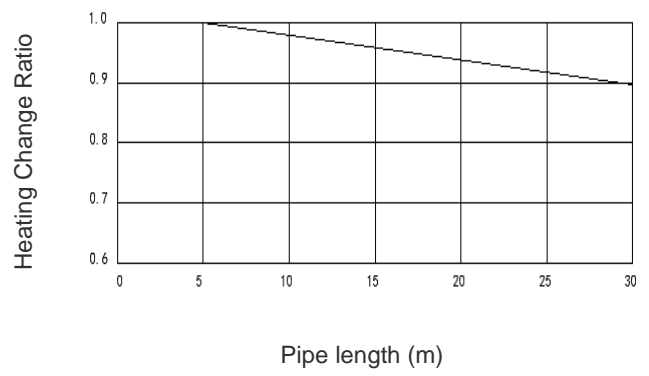
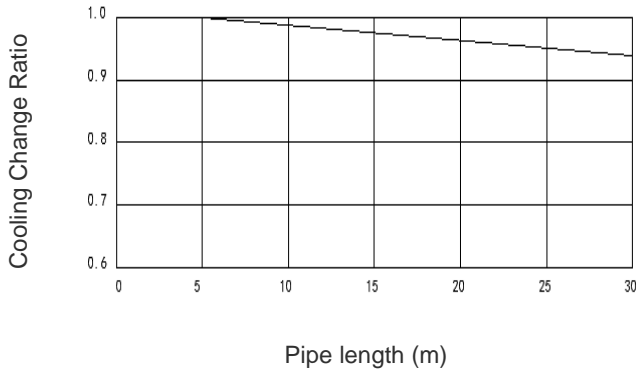

3.3. CORRECTION FACTORS ACCORDING TO DEFROSTING OPERATION

The heating capacity in the preceding paragraph, excludes the condition of the frost or the defrosting operation period. In consideration of the frost or the defrosting operation, the heating capacity is corrected by the equation below.

$$\text{Corrected heating capacity} = \text{Defrost Correction factor} \times \text{unit capacity}$$

OUTDOOR TEMPERATURE (°CDB)	-15	-10	-7	-5	0	7	10	15
Correction factor (humidity rate 85% RH)	0.95	0.95	0.89	0.85	0.81	1.0	1.0	1.0

Correction Factor

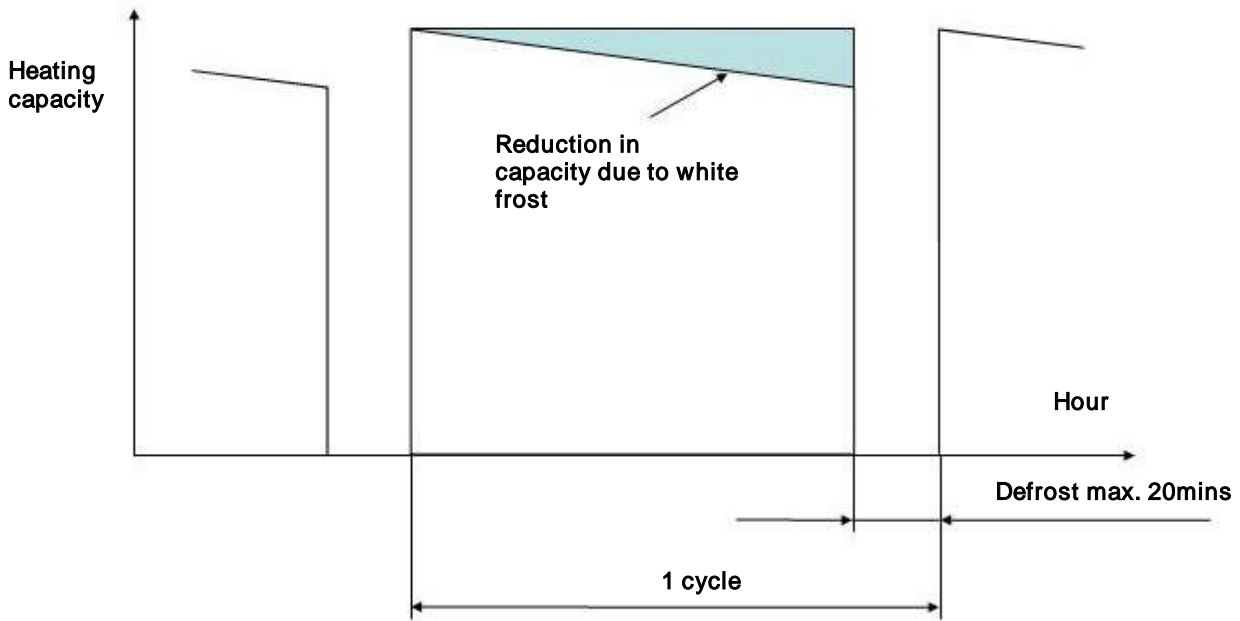

NOTE:

The correction factor is not valid for special conditions such as snowfall or operation in a transitional period.

4 SOUND DATA

4.1. RAC-25FXE

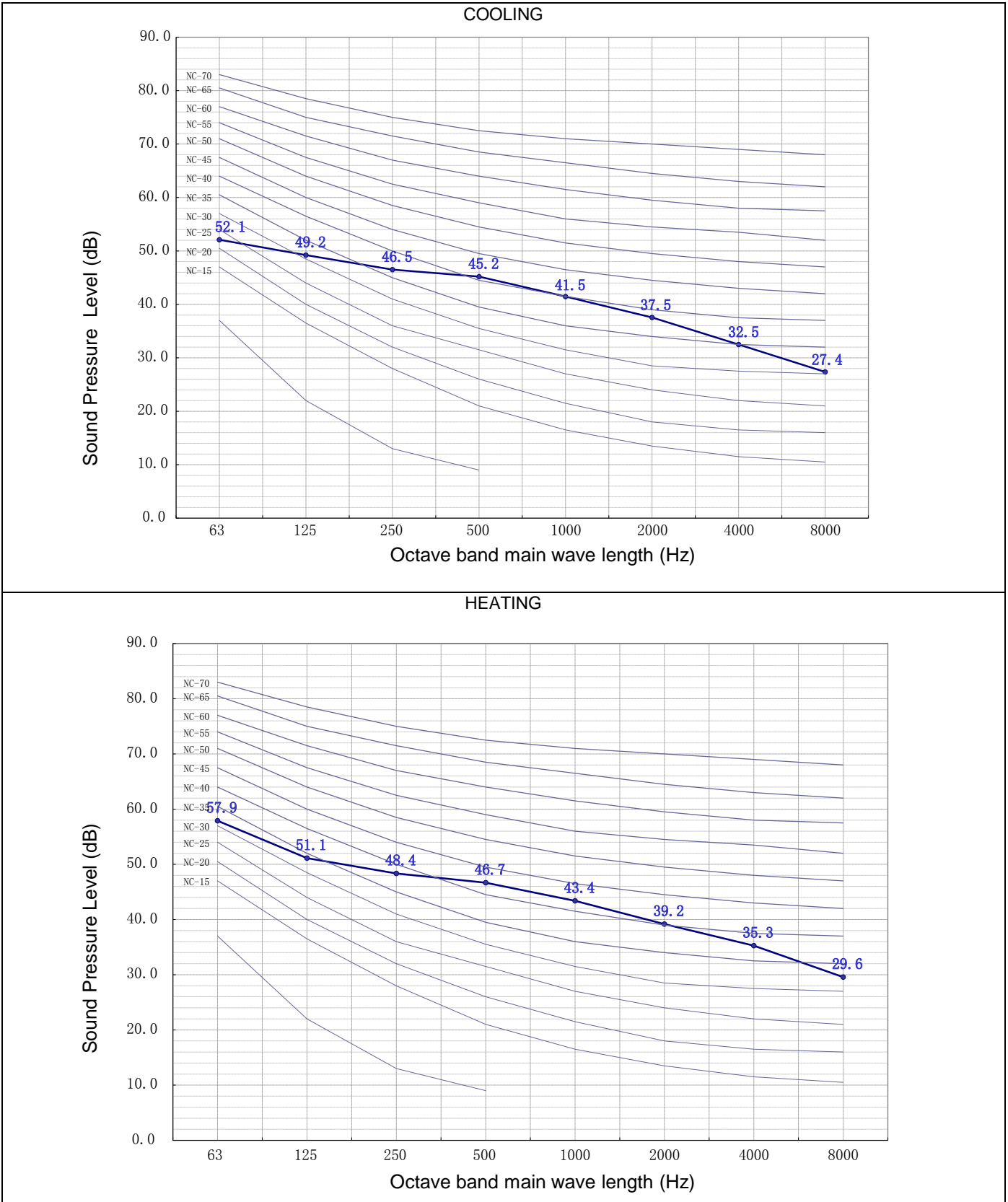

The Sound Pressure Level is based on the following conditions:

- 1 meter from the unit front surface and 1 meter from floor level

The above data was measured in an anechoic chamber. Please take into consideration reflected sound of your specific site

4.2. RAC-35FXE

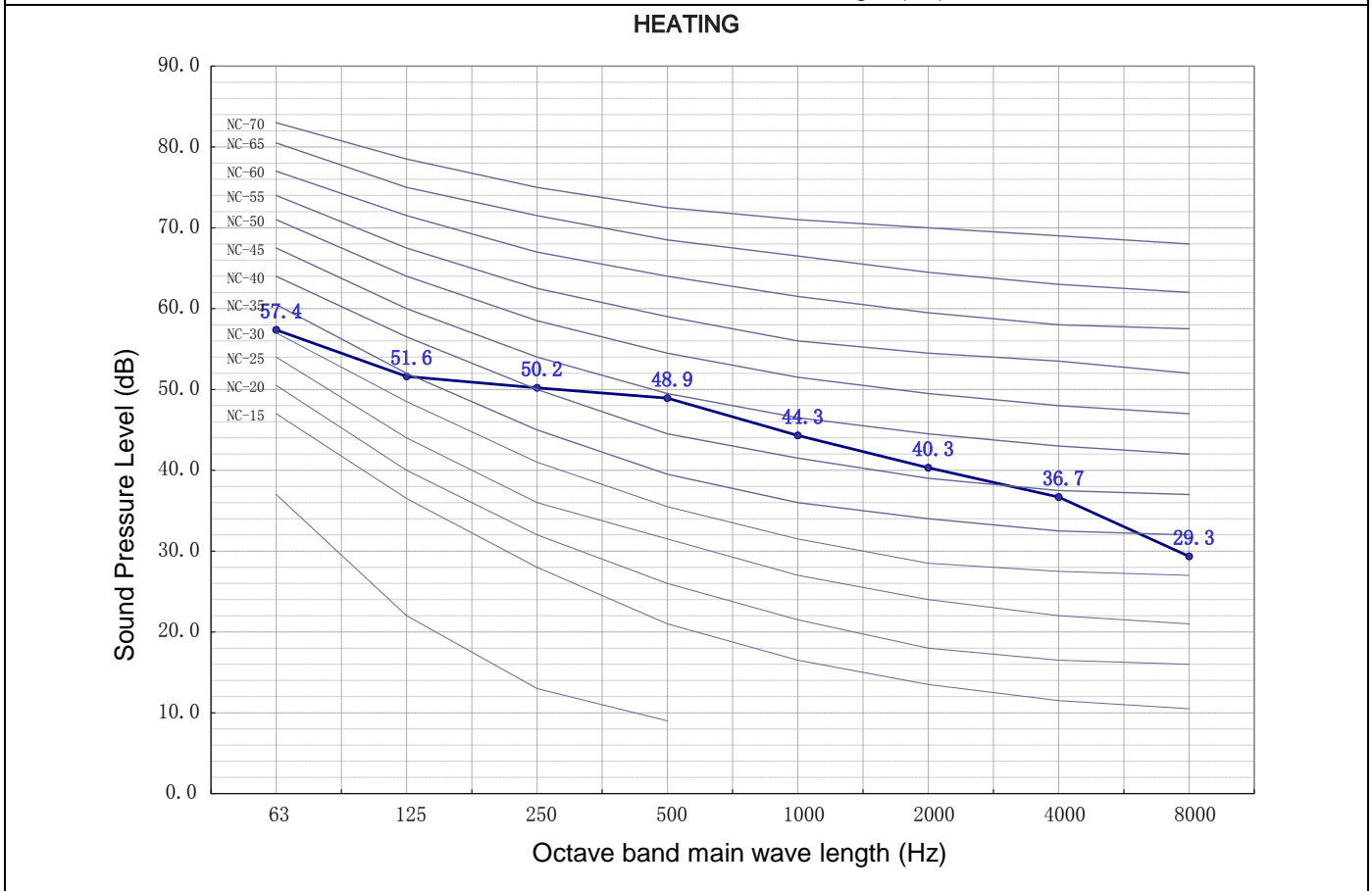
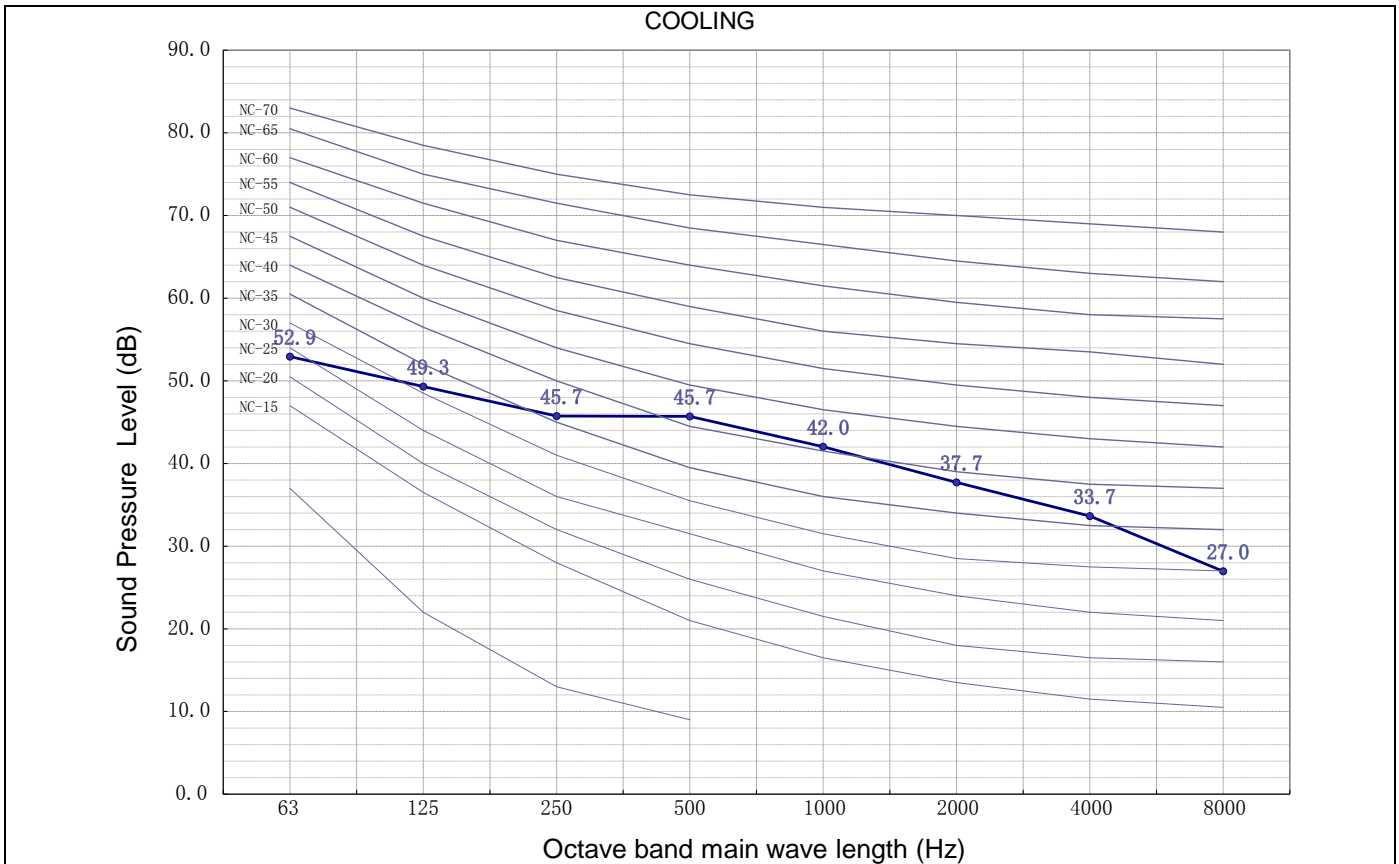

The Sound Pressure Level is based on the following conditions:

- 1 meter from the unit front surface and 1 meter from floor level

The above data was measured in an anechoic chamber. Please take into consideration reflected sound of your specific site

4.3. RAC-50FXE

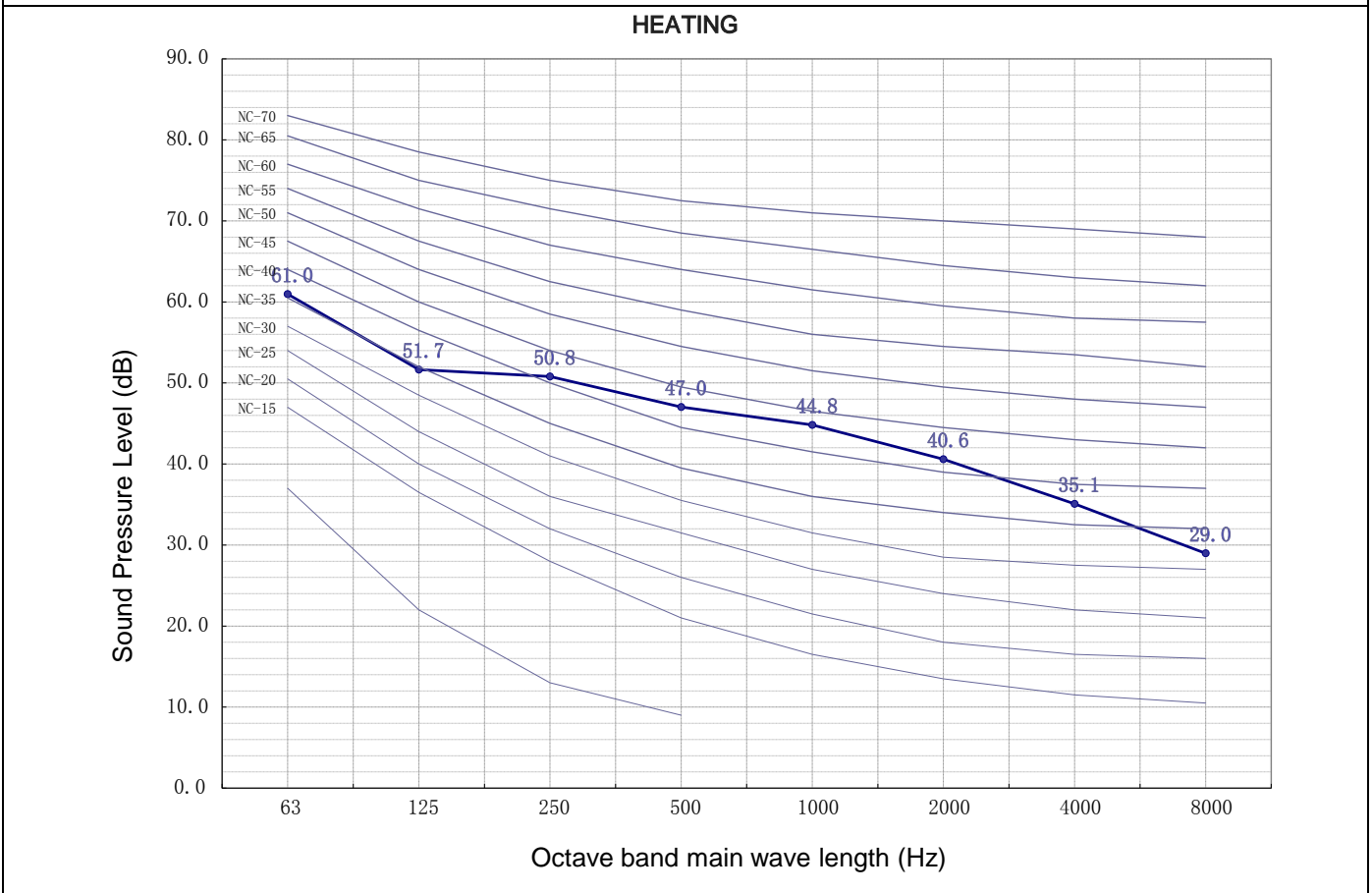
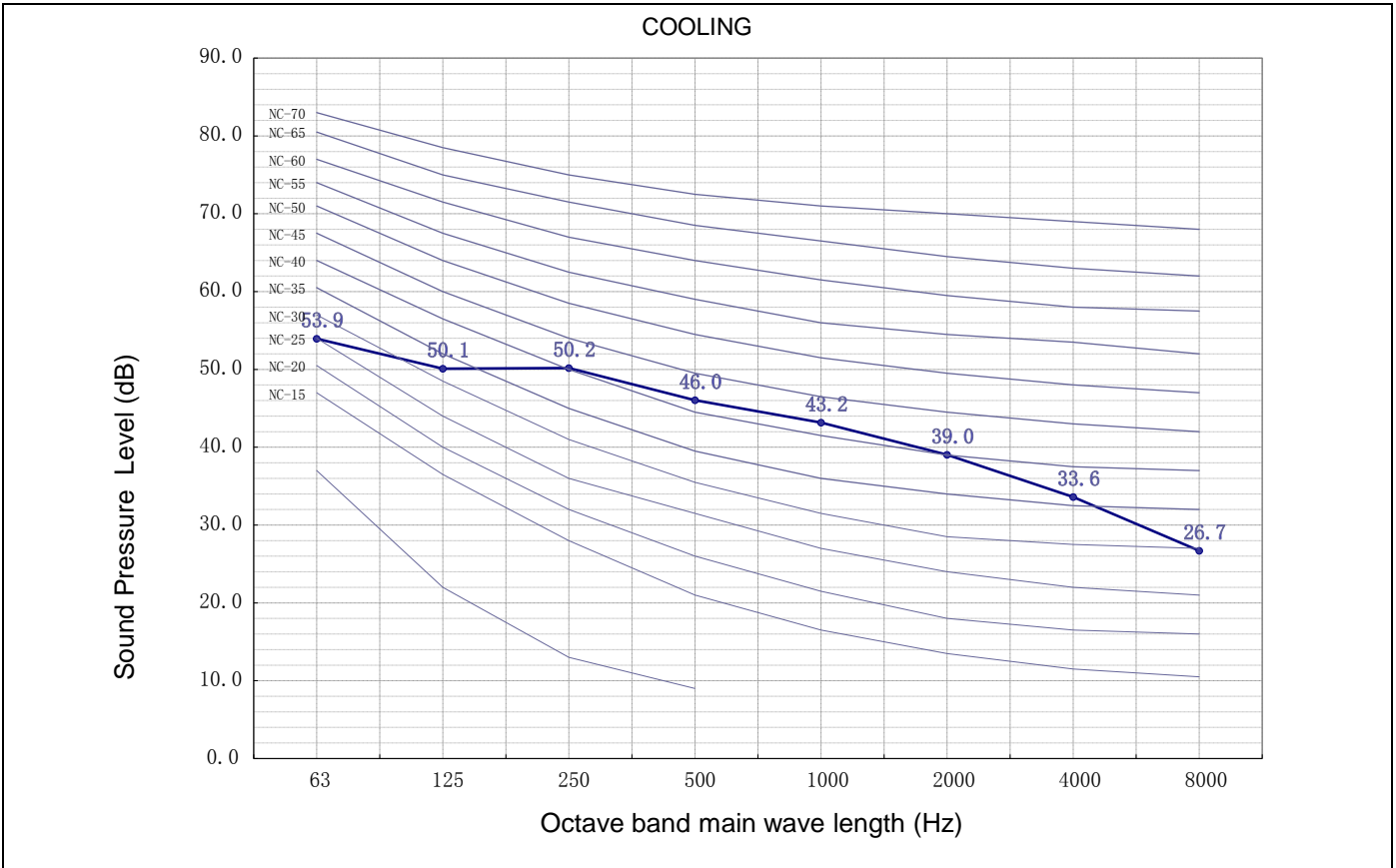

The Sound Pressure Level is based on the following conditions:

- 1 meter from the unit front surface and 1 meter from floor level

The above data was measured in an anechoic chamber. Please take into consideration reflected sound of your specific site

5 WORKING RANGE

5.1. POWER SUPPLY

Working Voltage	207V ~ 253V
Voltage Imbalance	Within a 3% Deviation from Each Voltage at the Main Terminal of Outdoor Unit
Starting Voltage	Higher than 85% of the Rated Voltage

5.2. WORKING RANGE

Applicable models:

RAC-25FXE
RAC-35FXE
RAC-50FXE

The temperature range is indicated in the following table.

Cooling

working range	min (°C)	max (°C)	rated (°C)
outdoor	-10	46	35
indoor	16	43	27

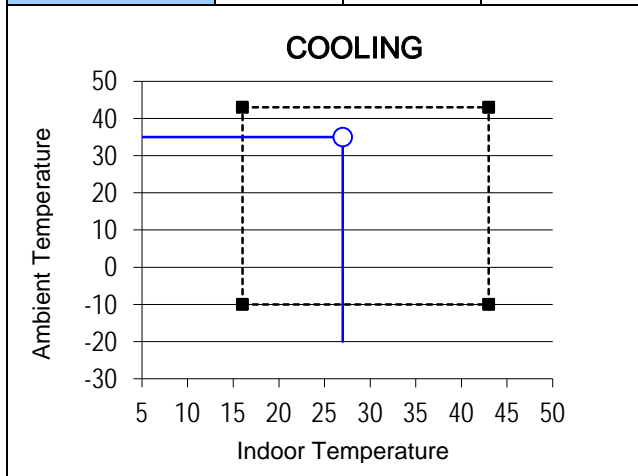

Heating

working range	min (°C)	max (°C)	rated (°C)
outdoor	-20	24	7
indoor	16	26	20

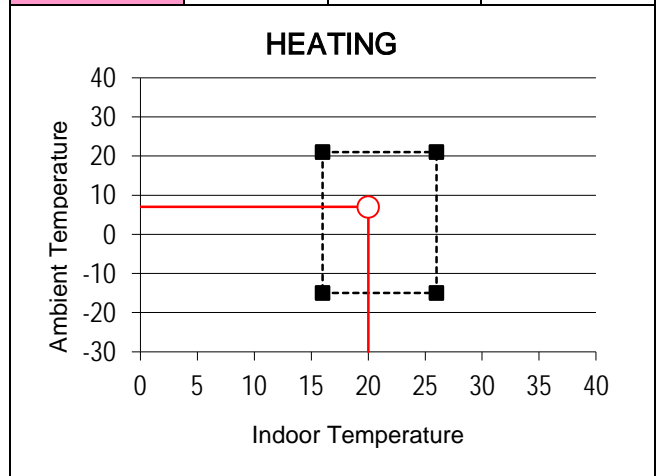

6 ELECTRICAL DATA

6.1. INDOOR UNIT

Model	Unit Main Power		Applicable Current		Indoor Fan Motor	
	VOL, PH, Hz	Fuse Rating (A)	STC	RNC	RNC	IPT
RAF-25RXE	230, 1, 50	3.15	(C) 2.87 (H) 3.50	(C) 5.13 (H) 4.87	0.75	38
RAF-35RXE	230, 1, 50	3.15	(C) 4.27 (H) 5.26	(C) 6.00 (H) 5.87	0.75	38
RAF-50RXE	230, 1, 50	3.15	(C) 6.33 (H) 7.19	(C) 9.13 (H) 11.74	0.75	38

VOL: Rated Unit Power Supply Voltage (V)
 Hz: Frequency (Hz)
 STC: Starting Current (A)

RNC: Running Current (A)
 PH: Phase (ϕ)
 IPT: Input (W)

6.2. OUTDOOR UNIT

Model	Unit Main Power				Compressor Motor					
	VOL, PH, Hz	Fuse Rating (A)	Min (V)	Max (V)	Locked Rotor Ampere (A)	STC	Cooling Operation		Heating Operation	
							RNC	IPT	RNC	IPT
RAC-25FXE	230, 1, 50	15	207	253	-	3.50	5.13	538	4.87	756
RAC-35FXE	230, 1, 50	15	207	253	-	5.26	6.00	933	5.87	1154
RAC-50FXE	230, 1, 50	25	207	253	-	7.19	9.13	1389	11.74	1579

VOL: Rated Unit Power Supply Voltage (V)
 HZ: Frequency (Hz)
 STC: Starting Current (A)

RNC: Running Current (A)
 PH: Phase (ϕ)
 IPT: Input (W)

NOTE:

1. The above compressor data is based on 100% capacity combination of indoor units at the rated operating frequency
2. This data is based on the same conditions as the nominal heating and cooling capacities.
3. The compressor started by an inverter, resulting in extremely low starting current.

7 WIRING DIAGRAM

7.1. RAF-25RXE, RAF-35RXE, RAF-50RXE

WIRING DIAGRAM

BLK: BLACK GRN: GREEN
 RED: RED WHT: WHITE
 GRY: GRAY YEL: YELLOW
 BLU: BLUE

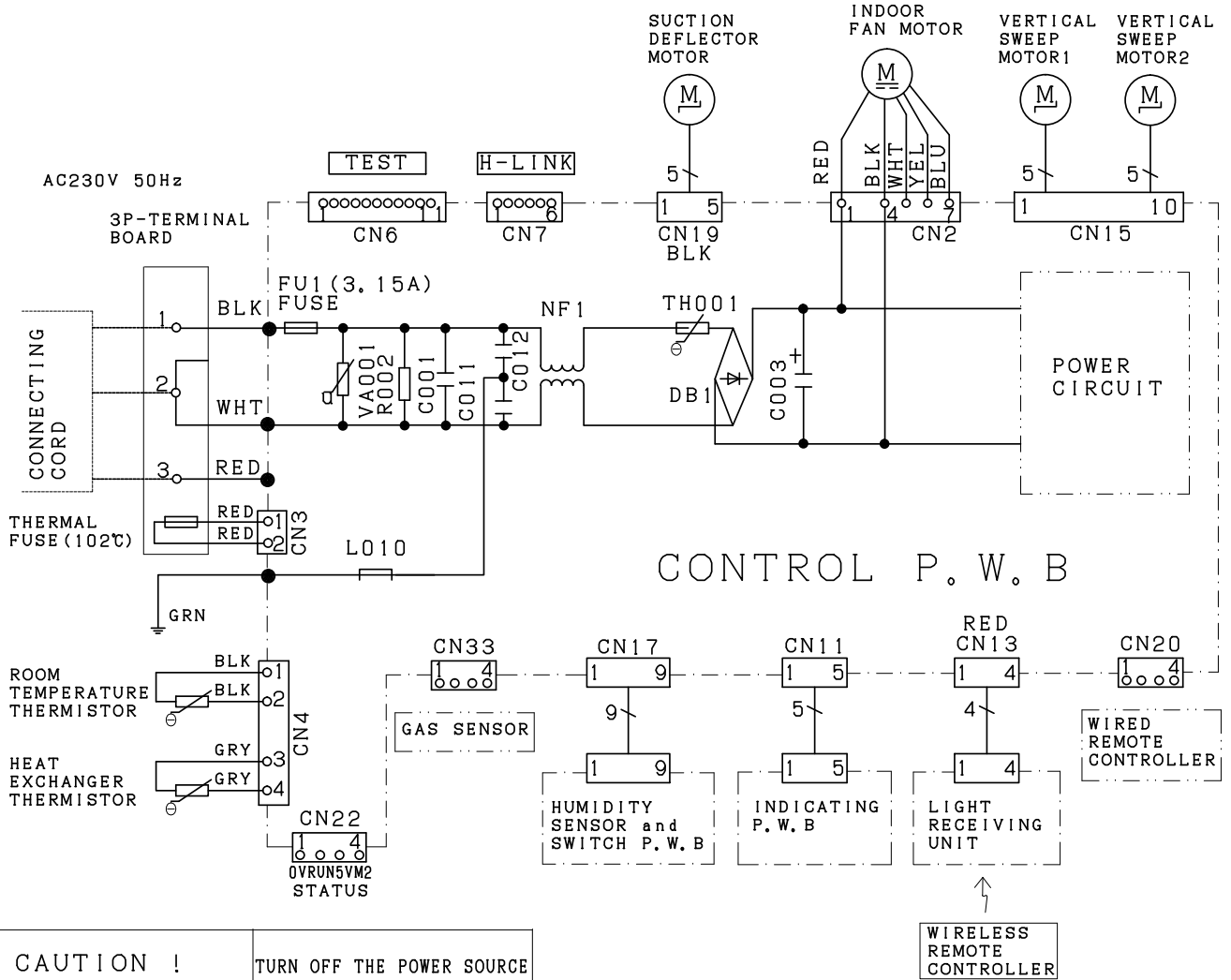

CAUTION ! HIGH VOLTAGE	TURN OFF THE POWER SOURCE DURING THE SERVICE WORK.
----------------------------------	--

7.2. RAC-25FXE, RAC-35FXE

RAC-25FXE, RAC-35FXE

WIRING DIAGRAM

BLU:BLUE RED:RED
 BLK:BLACK WHT:WHITE
 BRN:BROWN YEL:YELLOW
 GRN:GREEN GRY:GRAY

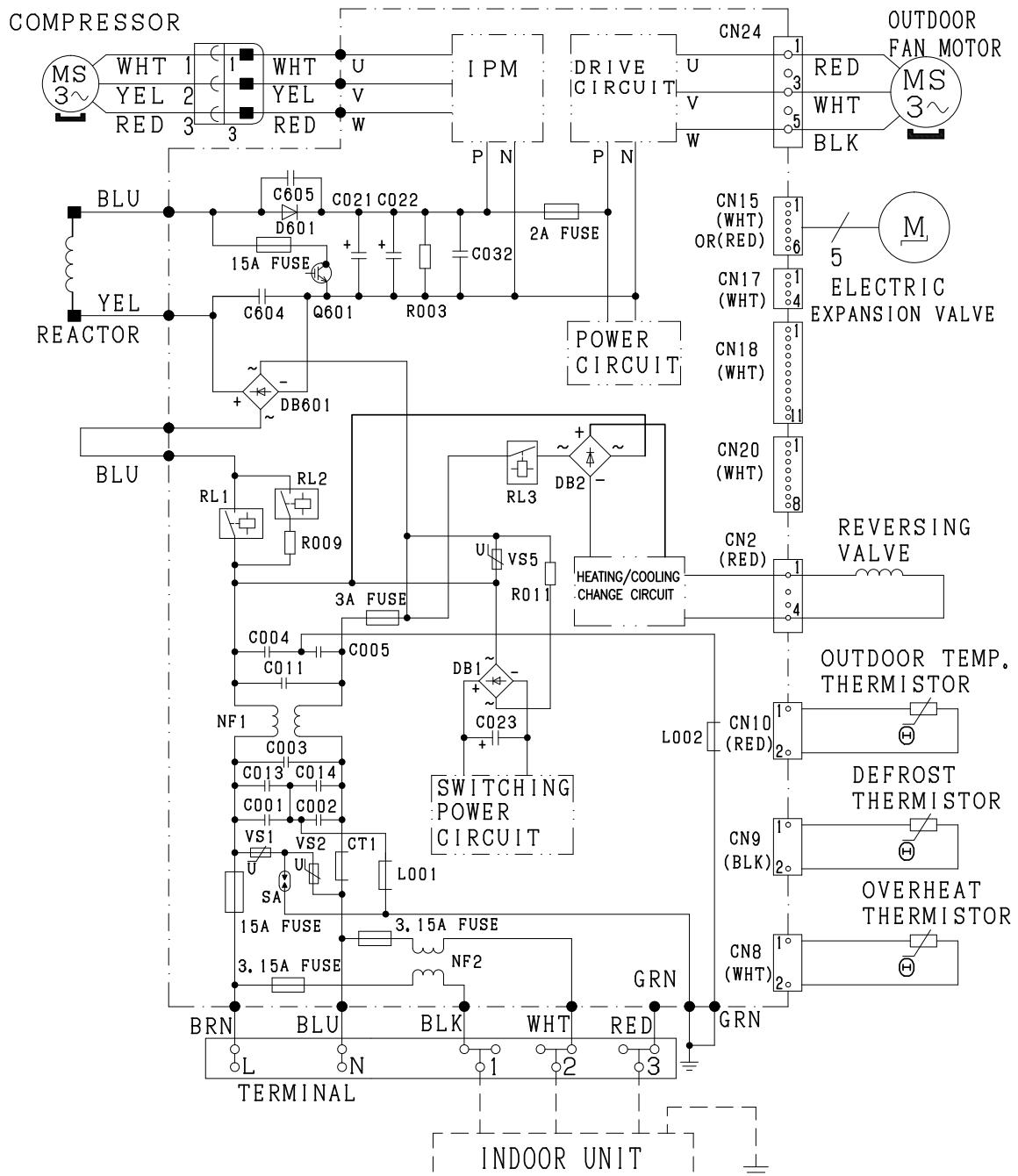

7.3. RAC-50FXE

RAC-50FXE

WIRING DIAGRAM

BLU:BLUE RED:RED BRN:BROWN YEL:YELLOW
 BLK:BLACK WHT:WHITE GRN:GREEN GRY:GRAY

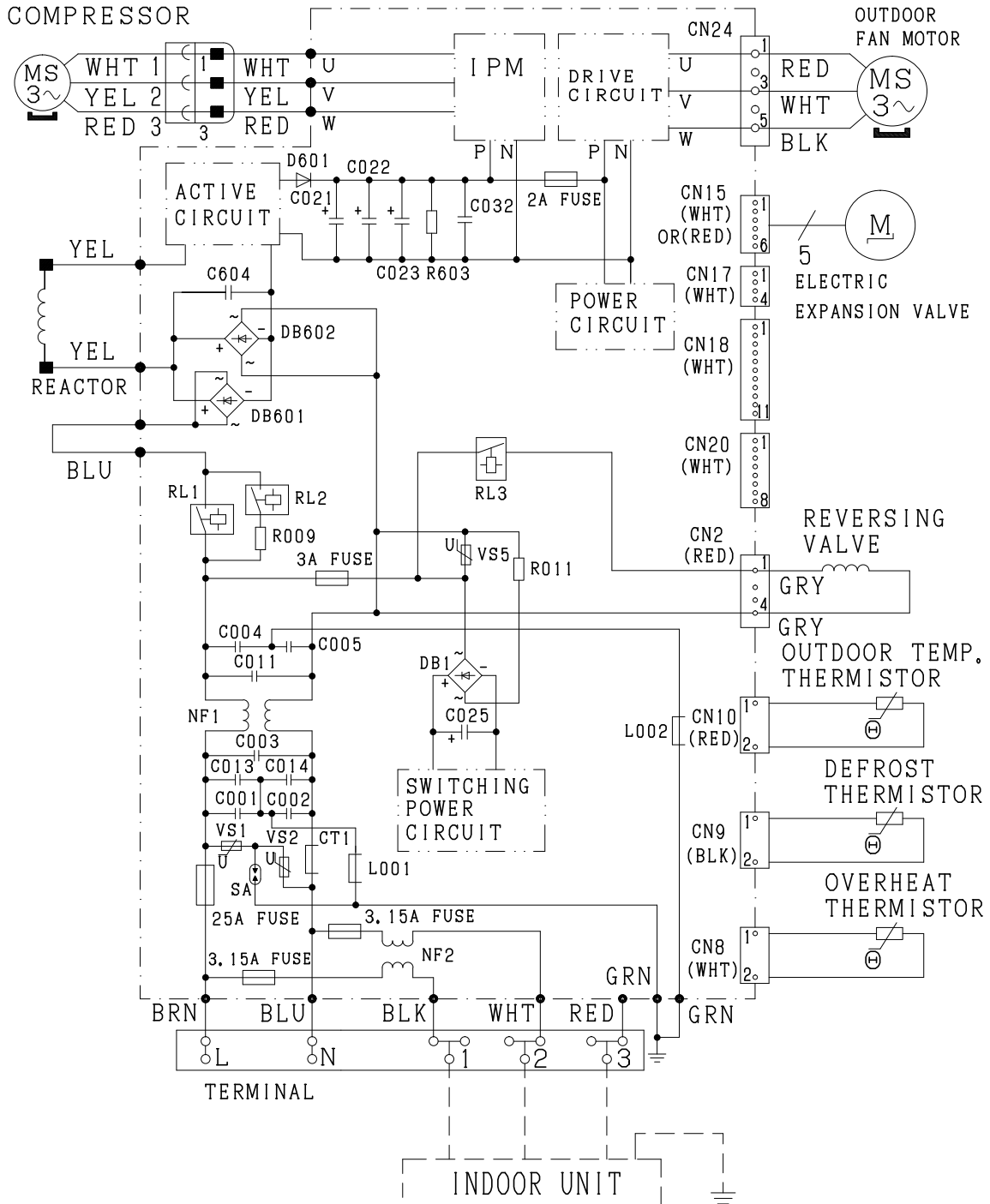

8 REFRIGERANT CYCLE

8.1. FLOOR TYPE: RAF-25RXE/RAC-25FXE, RAF-35RXE/RAC-35FXE

RAF-25RXE/RAC-25FXE, RAF-35RXE/RAC-35FXE

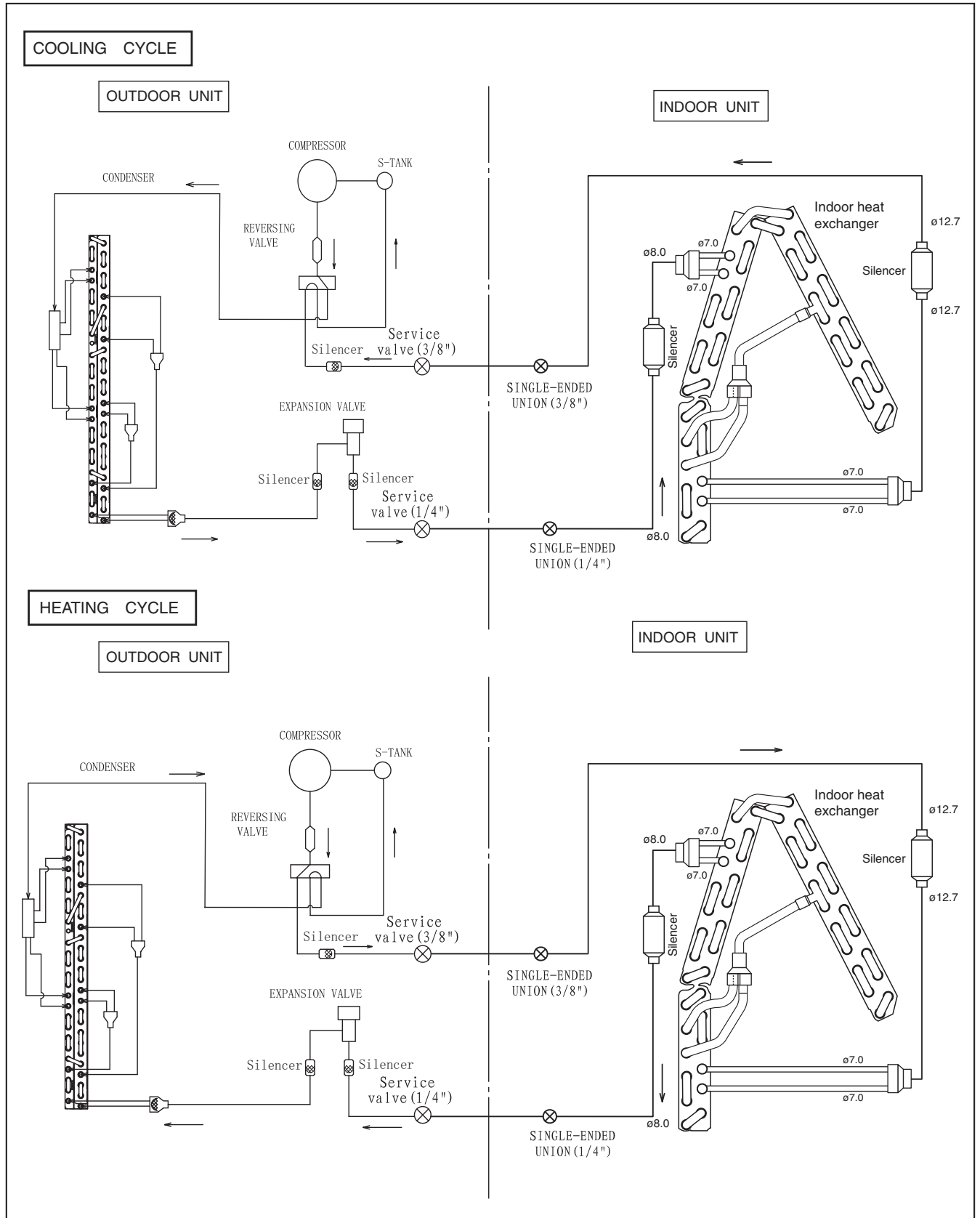

8.2. FLOOR TYPE: RAF-50RXE / RAC-50FXE

RAF-50RXE / RAC-50FXE

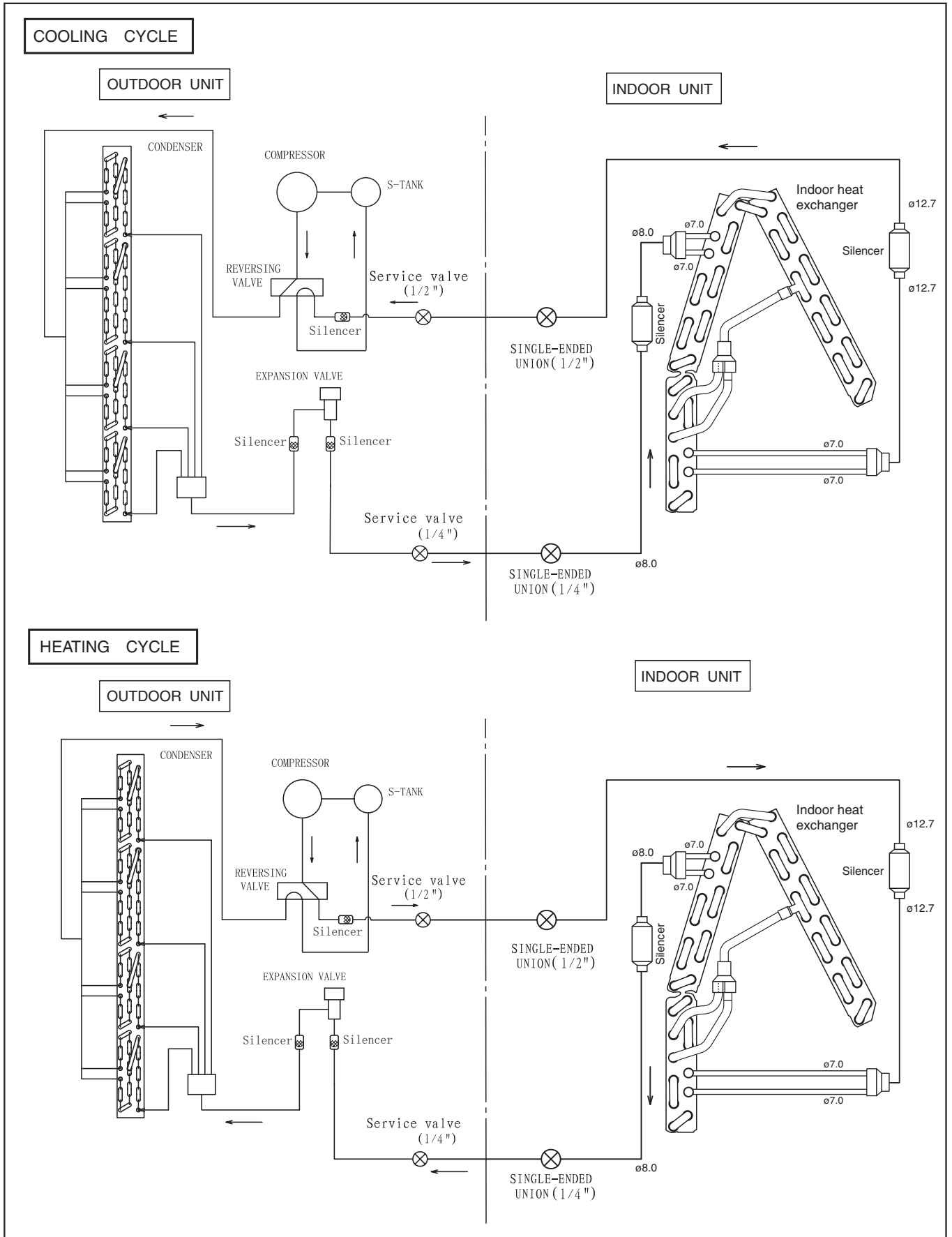

9 CONTROL AND FUNCTION

9.1. WIRELESS REMOTE CONTROL FUNCTION

BUTTONS	FUNCTION
	MODE Selector Use this button to select the operating mode. Every time you press this button, the mode will change from (AUTO) → (HEAT) → (DEHUMIDIFY) → (COOL) and → (FAN) cyclically.
	FAN SPEED Selector Button This determines the fan speed. Every time you press this button, the airflow rate will change from (AUTO) → (HIGH) → (MED) → (LOW) → (SILENT) (This button allows selection of optimal or preferred fan speed for each operation mode).
	START/STOP button Press this button to start operation. Press it again to stop operation.
	ECO button Use this button to set the ECO mode.
	POWERFUL button Use this button to set the POWERFUL mode.
	SILENT button Use this button to set the SILENT mode.
	INFO button 1) Press this button to display temperature for 10 seconds. 2) Press this button to check monthly power consumption. 3) Press this button to receive the current calendar and clock.
	ECO SLEEP TIMER button Use this button to set the ECO sleep timer.
	AUTO SWING (Vertical) button Controls the angle of the horizontal air deflector.
	EXTENDED AIR FLOW button Press this button during operation to start extended airflow operation.
	LEAVE HOME button Prevent the room temperature from falling too much by setting temperature 10°C~16°C when no one is at home.
	ONE TOUCH CLEAN button Drying indoor heat exchanger after cooling operation to prevent mildew.
WEEKLY TIMER buttons	
	ON/OFF TIMER button The device will turn on (off) and off (on) at the designated time.
	TIME button Press the button to set starting time of the program
	OK button Press the button to save the program. The button shall be pressed everytime after finishing a program setting.
	DELETE button 1) Press the button to delete the selected program. 2) Press the button for about 10 seconds by directing the remote controller towards the indoor unit while Mode A or B display blinks, programs for Mode A or B will be deleted both from the indoor unit and the remote controller after the beep sound from the indoor unit.
	DAY button Select the desired day of the week.
	PROGRAM NO. Button Press this button to select a program number.
	CANCEL 1) Press the button to cancel the current setting process on the screen. 2) Press the button by directing the remote controller towards the indoor unit, then weekly timer setting will be canceled from indoor unit after the beep sound from the indoor unit. The program setting remains in the remote controller.
	SEND button Press the button for about 3 seconds by directing the remote controller towards the indoor unit after finishing the program setting. Timer lamp on the indoor unit will blink rapidly and after the beep sound from indoor unit, TIMER lamp will light up.
	CLOCK button Press the button to set calendar and clock.
	WEEKLY TIMER MODE button 1) Select Mode A or Mode B. 2 modes can be set and stored as a weekly timer. 2) By pressing the button longer than 3 seconds, program setting screen will appear.



RAR-6NE4

9.2. AUTO CHANGEOVER

COOLING/HEATING mode is decided by the room temperature.

- A. COOLING/HEATING mode is decided during the **initial startup** of Automatic Operation
 Initial startup of Automatic Operation means the following either condition:
- Unit start up in Automatic Operation
 - Automatic Operation mode is pressed while the unit is running in manual mode

Startup room temperature	COOL / HEAT
>= Remote controller setting temperature	Unit runs in COOLING mode
< Remote controller setting temperature	Unit runs in HEATING mode

- B. COOLING/HEATING mode is decided in **intervals after the initial startup** of Automatic Operation (also known as Auto Changeover function)

Intervals	Duration
1 st interval	10 minutes
2 nd interval	15 minutes
Subsequent interval	Every 55 minutes

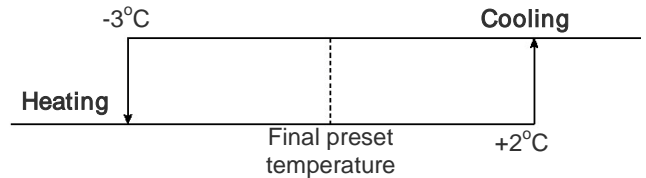

9.3. SHIFT VALUE

1. Press and hold (START/STOP) button and (ON) button.
2. Press (RESET) button on the same time. Release (RESET) button only, then release (START/STOP) and (ON) button once Screen 1 appears.



Screen 1

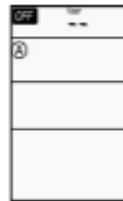

Screen 2

3. Press the (MODE) button to display fan mode (Screen 3).

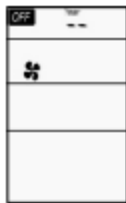

Screen 3

4. Press (START/STOP) and Screen 4 appear.

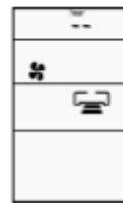

Screen 4

5. Select (FAN) (FAN SPEED) button to choose Heating Shift or Cooling Shift Mode (Screen 5).

By setting fan speed to HIGH or MED, it will go to Cooling Shift mode.
 By setting fan speed to LOW or SILENT, it will go to Heating Shift mode.

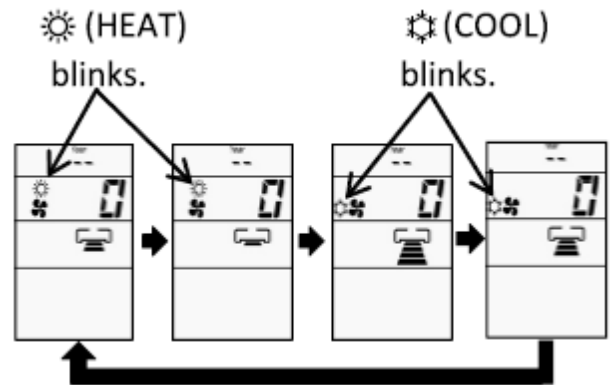

Screen 5

6. Press the Temperature button (V or ^) to adjust the shift value.



Decrease 3°C from the initial shift value setting.

Decrease 2°C from the initial shift value setting.

Decrease 1°C from the initial shift value setting.



The initial shift value setting.

Increase 1°C from the initial shift value setting.

Increase 2°C from the initial shift value setting.







Increase 3°C from the initial shift value setting.

NOTE:

1. There are total of 7 shift values ranging from -3 to 3.
2. The displayed shift value,  (HEAT) and  (COOL) symbol on the remote controller display will be disappear after 10 seconds
3. The changed shift value will remain unchanged after turned off the power.
4. If "0" is displayed on the remote controller display, it indicates the shift value is now at the initial setting.

9.4. OPERATION LOCK

1. HEATING MODE

- a) Press and hold  (ECO) and  (POWERFUL) buttons, press  (RESET) button on the same time. Release  (RESET) button only when Screen 1 appear, then release  (ECO) button and  (POWERFUL) button.



Screen 1



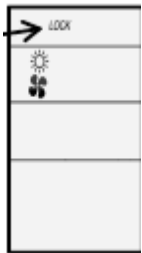

- b) Wait until only Screen 2 appear.





Screen 2

- c) The heating mode operation is locked.
- d) To unlock HEATING mode, repeat step (a). After all operations mode symbols displayed for 10 seconds, the operation mode symbol before cancellation will be display. The heating mode operation is unlocked.

2. COOLING AND DEHUMIDIFYING MODE

- a) Press and hold  (ECO) and  (SILENT) buttons for at least 5 seconds when the remote controller is OFF.
- b) Wait until only  and  displayed on the screen. The cooling and dehumidifying modes operation is locked.
- c) To unlock HEATING mode, repeat step (a). After all operations mode symbols displayed for 10 seconds, the operation mode symbol before cancellation will be display. The cooling and dehumidifying mode operation is unlocked.

9.5. SETTING THE PREVENTION OF MUTUAL INTERFERENCE

1. Please ensure the other indoor unit is OFF.
2. Press  (PROGRAM NO.) button,  (ON TIMER) button and  (RESET) button simultaneously. The remote controller will display Screen 1 and followed by Screen 2. The indoor unit beeps to indicate that it has just received the signal from remote controller.



Screen 1



Screen 2







NOTE:

1. If indoor unit still not receive the correct signal from the correct remote controller, setting shall be made again. By setting again for the 2nd time, the signal address will change from B to A, then repeat again for the 3rd time.

9.6. INTERMITTENT FAN SPEED SETTING

The intermittent fan control during thermo off in Heating Mode can be changed by the remote controller. (This procedure should be done only by service personnel.) It is possible to select from 3 patterns.

PROCEDURE

1. Press  [START/STOP] button,  [Mon-Sun] button and press  [RESET] button simultaneously. Release  [RESET] button only and make sure that all marks on the remote controller display are indicated, then release  [START/STOP] button and  [Mon-Sun] button. Remote controller now enters "Intermittent Fan Control Change Mode".

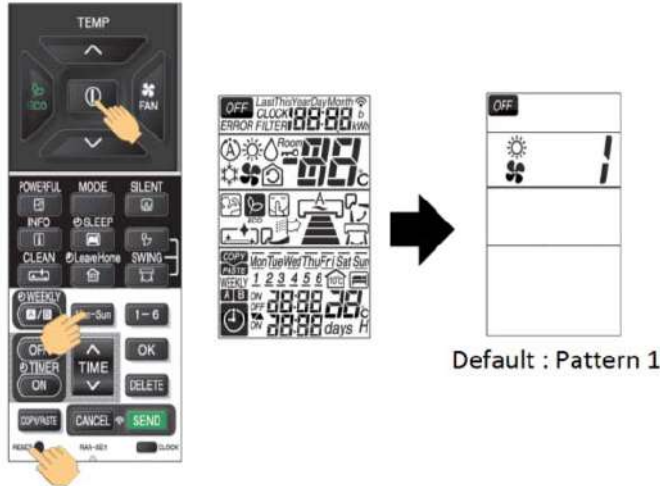

2. Press [ROOM TEMPERATURE setting] [\wedge (UP)]/[\vee (DOWN)] buttons. (The intermittent pattern changed with indoor unit beep sound.)

Transmission sign lights up with beep from indoor unit simultaneously.

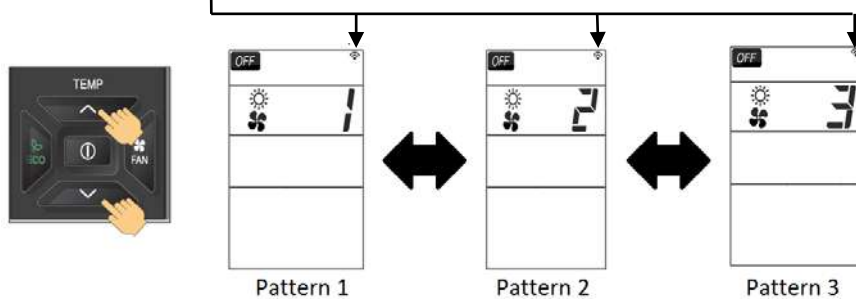

	Pattern 1	Pattern 2	Pattern 3
Single Model	Continuous	30sec ON / 210sec OFF repeatedly	50sec ON / 190sec OFF repeatedly
Multi Model	30sec ON / 210sec OFF repeatedly	50sec ON / 190sec OFF repeatedly	Continuous



NOTE :

- (1) The indication of the selected intermittent pattern will disappear after 10 seconds.
- (2) The selected intermittent pattern will remain unchanged after the unit is turned off.

9.7. FAN SPEED SETTING IN THERMO OFF IN COOLING

The fan speed in Cooling Mode during thermo off can be changed by the remote controller.
(This procedure shall be implemented strictly by service personnel only.)
It is possible to return it to the default setting.

PROCEDURE

Press  [POWERFUL] button and  [TIME ^ (UP)] button simultaneously for about 5 seconds when the remote controller is OFF.

Transmission sign lights up with beep from indoor unit simultaneously.

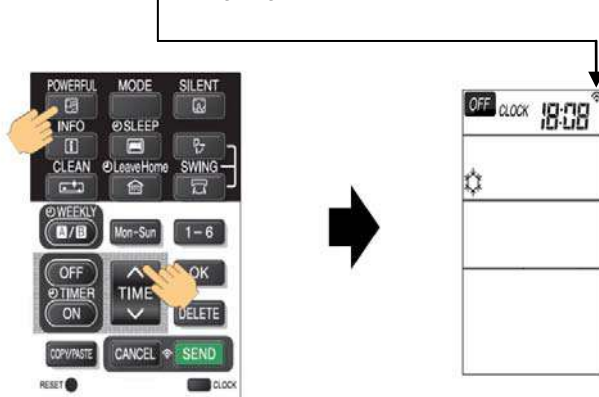



Beep sound pattern :
 1) Default setting : Short beep
 2) Changed setting : Double beep

	Fan speed during thermo off
Default Setting	Ultra low
Changed Setting	Set fan speed (When auto fan speed is set, the fan speed is low)

NOTE :

- (1) The selected fan speed will remain unchanged after the unit is turned off.
- (2) If Timer reservation has been set, it will be canceled.
- (3) During time setting and timer setting, this operation cannot be set.

9.8. ERROR CODE INFORMATION

1. In case failure occurs to the air conditioner, by pressing  (INFO) button, an error code will be displayed.
2. Direct the remote controller towards the receiver of indoor unit (within 2 meters in from of indoor unit) and press  (INFO) button.
3. Wait for 2 seconds for signal transmission and the error code will be displayed.

	TIMER LAMP BLINKING	LD301 BLINKING	CODE	MEANING
INDOOR	-	-	000 00	Normal
	1 time	-	001 00	Refrigerant cycle fault
	2 times	-	-	Outdoor unit is under forced operation
	3 times	9 times	003 00	Communication error between indoor and outdoor units
	9 times	-	009 00	Indoor thermistor
	10 times	-	010 00	Abnormal rotating numbers
	12 times	9 times	012 00	Communication error between indoor and outdoor units
	13 times	-	013 00	EEPROM data reading error
	18 times	-	018 00	Cleaning defective
	20 times	-	020 00	Human sensor defective
OUTDOOR	4 times	2 times	002 01	Peak current cut
	4 times	3 times	003 01	Compressor abnormal low speed rotation
	4 times	4 times	004 01	Compressor switching failure
	4 times	5 times	005 01	Overload lower limit cut
	4 times	6 times	006 01	OH thermistor temperature rise
	4 times	7 times	007 01	Abnormal outdoor thermistor
	4 times	9 times	009 01	Communication error
	4 times	10 times	010 01	Abnormal power source
	4 times	11 times	011 01	Fan stop for strong wind
	4 times	12 times	012 01	Fan motor fault
	4 times	13 times	013 01	EEPROM reading error
	4 times	14 times	014 01	Active converter defective
	4 times	15 times	015 01	Abnormal PWB circuit
	4 times	16 times	016 01	High load stop

9.9. ADDITIONAL FUNCTION VIA DIP-SWITCH SETTINGS

A new DIP Switch is available on the PWBs of the indoor unit that provide additional functions via the settings on the switches.

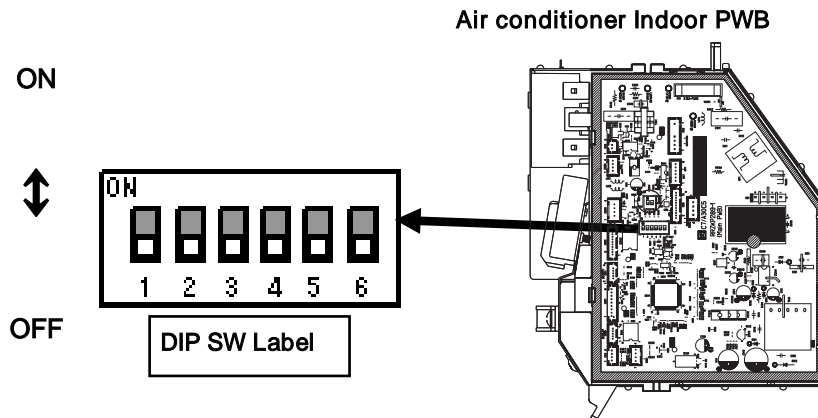

Pin No.	Function	Switch Position / Setting					
		OFF	Enable	ON	Disable		
1	AUTO RESTART function	OFF	Enable	ON	Disable		
2	DRY CONTACT function	OFF	Disable	ON	Enable		
3	DRY CONTACT Logic Select	OFF	HI Input Active	ON	LO Input Active		
4	HEATING / COOLING ONLY MODE SELECT	OFF	NORMAL (HEAT AND COOL)	OFF	HEATING ONLY	ON	COOLING ONLY
5		OFF		ON	OFF		
6	REMOCON ID SELECT ❖1	OFF	SELECT ID A	ON	SELECT ID B		

NOTE:

- ❖1 The setting of pin no. 6 is disabled for this model. Please refer to **9.5 SETTING THE PREVENTION OF MUTUAL INTERFERENCE**.

9.9.1. AUTO RESTART FUNCTION

The AUTO RESTART function can be enabled or disabled by setting Pin No. 1 on the DIP SWITCH above to the ON or OFF position accordingly.





















9.9.2. HEATING/COOLING ONLY MODEL SELECTION

When this function is enabled, the operation mode could be locked to either Heating Only (Heating or Fan) or Cooling Only (Cooling, Fan or Dehumidifying) by setting the Pin No. 4 and 5 accordingly.





LOCKED MODE	REMARKS
HEATING ONLY	Unit will not enter into Cooling mode although cooling mode is selected using the remote controller.
COOLING ONLY	Unit will not enter into Heating mode although heating mode is selected using the remote controller.

10 OPTION LIST

10.1. WIRED REMOTE CONTROL – SPX-RCDB



 <p>RAR-5G2 (SPX-RCDB)</p>	BUTTONS	FUNCTION
		MODE Selector Use this button to select the operating mode. Every time you press this button, the mode will change from  (AUTO) →  (HEAT) →  (DEHUMIDIFY) →  (COOL) and →  (FAN) cyclically.
		FAN SPEED Selector Button This determines the fan speed. Every time you press this button, the airflow rate will change from  (AUTO) →  (HIGH) →  (MED) →  (LOW) →  (SILENT) (This button allows selection of optimal or preferred fan speed for each operation mode).
		ON/OFF button Press this button to start operation. Press it again to stop operation.
		SLEEP button Use this button to set the SLEEP timer.
		SET button Timer setting reservation.
		OFF button Select the turn OFF timer.
		ON button Select the turn ON timer.
		CANCEL button Cancel timer reservation.
		AUTO SWING (Vertical) button Controls the angle of the horizontal air deflector.
	ROOM TEMPERATURE setting button Value will change quicke when keep pressing.	

10.1.1. SHIFT VALUE

1. Press and hold  (ON/OFF) button and  (ON TIMER) button at the same time while giving a single press on the RESET button until remote controller now enter 'Shift value change mode'.
2. Press  (ON/OFF) button so that the display indicates  (FAN) speed.
3. Select  (FAN SPEED) button to choose Heating Shift or Cooling Shift Mode.

By setting fan speed to HIGH  or MED  , it will go to Cooling Shift mode.

By setting fan speed to LOW  or SILENT  , it will go to Heating Shift mode.



4. Press  (ROOM TEMPERATURE) button to change the shift value (-3°C ~ 0 ~ 3°C).
5. Press  (ON/OFF) button to end 'Shift value setting mode'.



NOTE:

1. There are total of 7 shift values ranging from -3 to 3.
2. The changed shift value will remain unchanged after turned off the power.

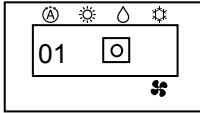
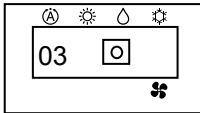
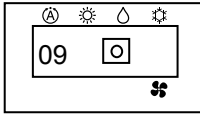
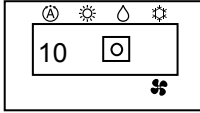
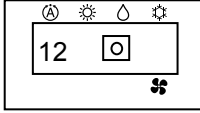
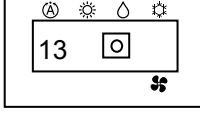
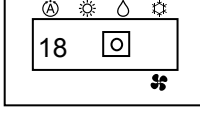
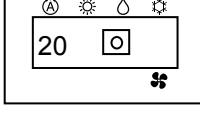
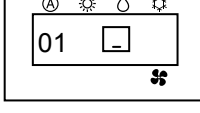
10.1.2. ERROR CODE INFORMATION

- In case failure occurs to the air conditioner, the error code will constantly appear on the wired remote controller display.

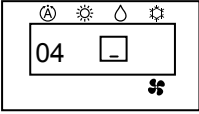
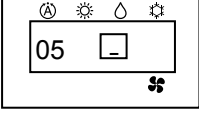
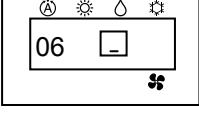
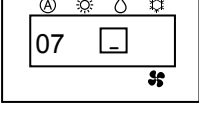
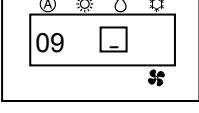
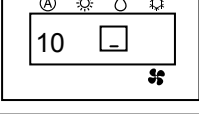
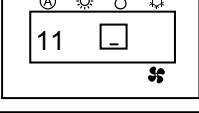
	TIMER LAMP BLINKING	LD301 BLINKING	CODE	MEANING
INDOOR	-	-	-	Normal
	1 time	-		Refrigerant cycle fault
	2 times	-	-	Outdoor unit is under forced operation
	3 times	9 times		Communication error between indoor and outdoor units
	9 times	-		Indoor thermistor
	10 times	-		Abnormal rotating numbers
	12 times	-		Communication error between indoor and outdoor units
	13 times	-		EEPROM data reading error
	18 times	-		Cleaning defective
	20 times	-		Human sensor defective
OUTDOOR	4 times	2 times		Peak current cut
	4 times	3 times		Compressor abnormal low speed rotation

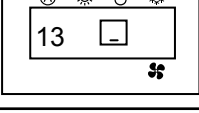
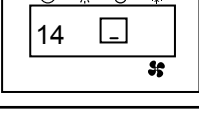
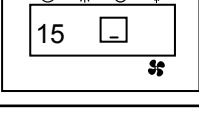
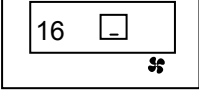
	TIMER LAMP BLINKING	LD301 BLINKING	CODE	MEANING
OUTDOOR	4 times	4 times		Compressor switching failure
	4 times	5 times		Overload lower limit cut
	4 times	6 times		OH thermistor temperature rise
	4 times	7 times		Abnormal outdoor thermistor
	4 times	9 times		Communication error
	4 times	10 times		Abnormal power source
	4 times	11 times		Fan stop for strong wind
	4 times	12 times		Fan motor fault
	4 times	13 times		EEPROM reading error
	4 times	14 times		Active converter defective
	4 times	15 times		Abnormal PWB circuit
	4 times	16 times		High load stop

10.2. H-LINK ADAPTOR – PSC 6RAD

10.2.1. SAFETY SUMMARY

DANGER:

- DO NOT pour water into the remote control switch (hereafter called “controller”). This product is equipped with electrical parts. This will cause serious electrical shock.

WARNING:

- DO NOT perform installation work and electrical wiring connection by yourself. Contact your distributor or dealer of HITACHI and ask then for installation work and electrical wiring by service person. The specified cable should be used to connect (i) room air conditioner and adaptor, and (ii) controller and adaptor.



CAUTION:



- DO NOT install the indoor unit, outdoor unit, controller and cable as such places as:
 - where there is oil vapor and dispersion of oil
 - where there is sulfuric environment (near the hot springs)
 - where there is a flammable gas
 - where there is salty environment (near the sea)
- DO NOT install the indoor unit, outdoor unit, controller and cable within approximately 3 meters from strong electromagnetic wave radiators, such as medical equipment. In case that the controller is installed in a place where there is electromagnetic wave direct-radiation, shield the controller and cables by covering with the steel box and running the cable through the metal conduit tube.
- In case that there is electric noise at the power source for the indoor unit, provide a noise filter.

10.2.2. INSTALLATION WORK

■ Before installation

Check the contents and the number of the accessories in the packing.

Adaptor	 <p>With two 1.8m cables</p>
1 piece of cover for hiding the covering	 <p>Attached 2 sided tapes</p>
Two-sided tape for attaching to Adaptor	 <p>110x40x3mm</p>

2 connectors for H-Link connection		
2 tapping screws for attaching to wall		φ3.0 x 10mm
2 screws for attaching to wooden wall		φ3.1 x 16mm

- 1) RAC adaptor can be installed to the wall as well as on the air conditioner itself
- 2) Install RAC adaptor in the vertical surface as shown below.

Upper side

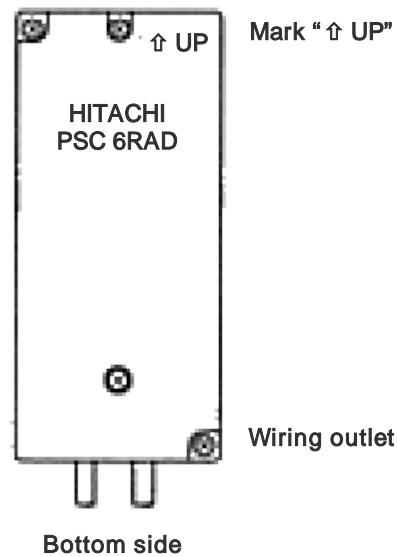

- 3) Installation procedure
 - a) When installing to the wall.
 - i) Fix the adaptor with 2 screws. Tapping screw is for metal surface, and other screw is for wooden surface.

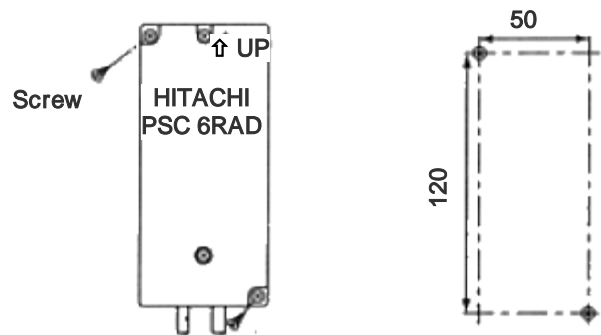

- ii) When using the cover
It can be installed at the right and left side of room air conditioner. Fix the cover and RAC adaptor with the two-sided tape (accessory).

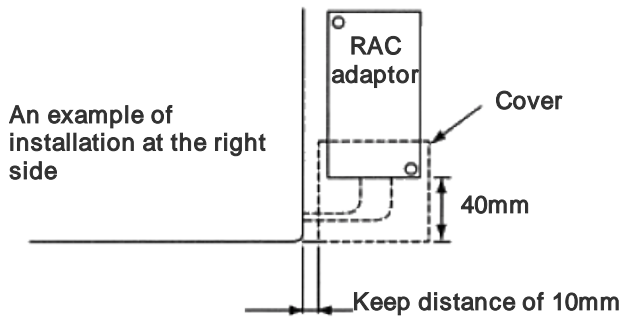

- b) When installing on the room air-conditioner
 In case that it cannot be installed to the wall due to the space or material problem, install the RAC adaptor with the two-sided tape (accessory) on the room air-conditioner.
- i) Confirm if the piping cover of the unit can be removed when performing the service maintenance, and then fix the RAC adaptor in the side of room air-conditioner with two-sided tape. (Available at the right as well as left side)
 - ii) Clean the surface to be installed with a dry cloth.

NOTE:

- Consider the following points since the adhesiveness changes according to the environmental conditions (temperature, humidity etc)
- The adhesiveness is decreased when there is humidity or oil.
- Warm the adhesive part and installation place of the two-sided tape to avoid the decrease of the adhesiveness in case the ambient temperature is low.
- DO NOT touch the adhesive part by fingers nor re-attach it many times. The adhesiveness has decreased and the RAC adaptor may fall off.
- DO NOT apply any force within 24 hours after installation.

10.2.3. ELECTRICAL WIRING

■ System configuration

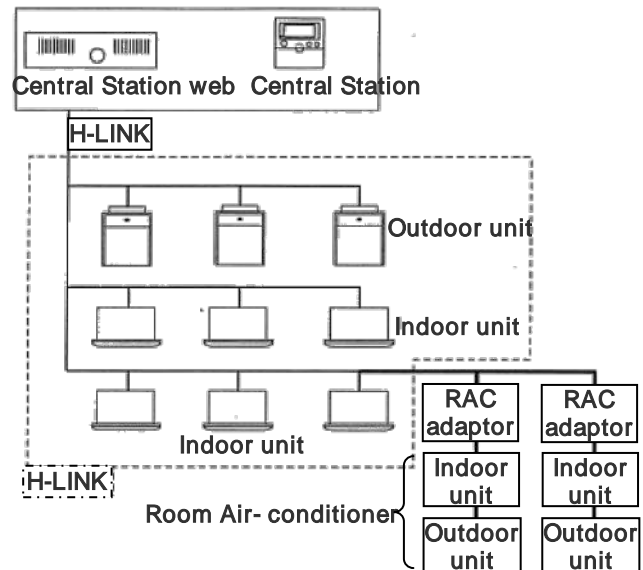

CAUTION:

- Turn OFF the power supply of the room air-conditioner of the central control device when performing the wiring work
- DO NOT run all the H-LINK cable or power supply cable along the other signal cable, or malfunction may occur due to the noise, etc. If it is required to run along the other transmission cable, separate the cable more than 30cm, or run the cable through the metal tube and earth the tube.
- Follow local codes and regulations when performing electrical wiring and earth wiring.
- Transmissions cable used in H-LINK shall be 2 cores cable (0.7mm² to 1.25mm² for model: VCTF, VCT, CVV, MVVX, CVVX, VVR, VVF) or 2 cores twisted pair cable (model: KPEV, KPEV-Spec). Total length of cable shall be below 1000mm.
- DO NOT use wire with more than 3 cores.

■ Internal components and Wiring connections

Check the contents and the number of the accessories in the packing.

- Access
 Open the cover by removing the ① and ② screws.



- Wiring Connection
 Connection with Room Air-Conditioner
 - i) Remove the front cover of the room air-conditioner and the cover of electrical box.
 - ii) The cable attached with the connector of the RAC adaptor shall be connected with the connector of indoor PCB

- iii) Install the electrical box cover paying attention not to clamp the cable. Read the installation manual of each room air-conditioner for confirming how to connect and how to assemble the cable of the RAC adaptor.

CAUTION:

- Disconnect the power plug before performing this work
- Turn OFF the break power source in case the power is supplied from the outdoor unit.

- Connection of Transmission Cable

H-LINK transmission cable connecting to RAC adaptor shall be connected to H-LINK.

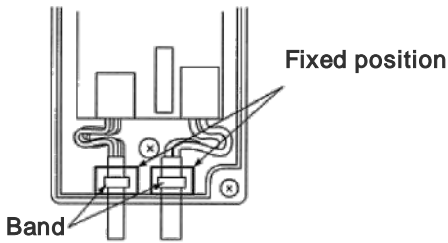
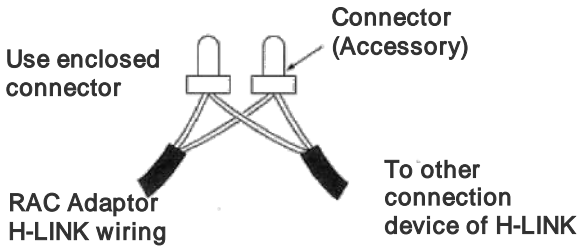

CAUTION:

- DO NOT connect incorrect wiring. It may cause the failure of the RAC Adaptor. Especially pay attention not to apply high voltage e.g. AC400/230V.
- DO NOT perform the wiring work while power to the central station or the RAC Adaptor is still being supplied. It may cause malfunction. Turn OFF devices when performing the wiring work.
- The RAC Adaptor side cable should not overload to the connector.
- DO NOT clamp the cable when attaching the RAC adaptor cover.
- Band should not be loose and in fixed position.

10.2.4. DIP SWITCH SETTING

- 1) Switch OFF the power of room air conditioner before setting the DIP switch. If the power is ON, the settings are INVALID.
- 2) The position of the DIP switch is shown below.

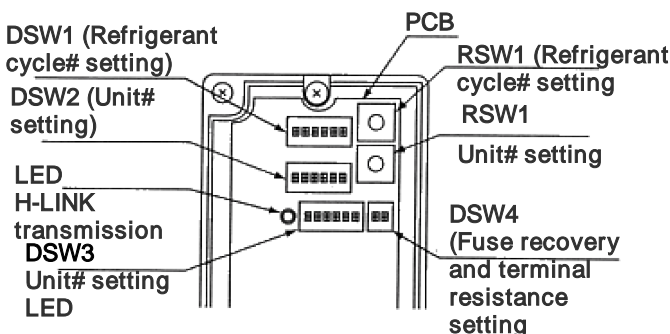

CAUTION:

- DO NOT turn ON various pins of DSW1 and DSW2

- 3) Set the refrigerant cycle# by RSW1 and DSW1

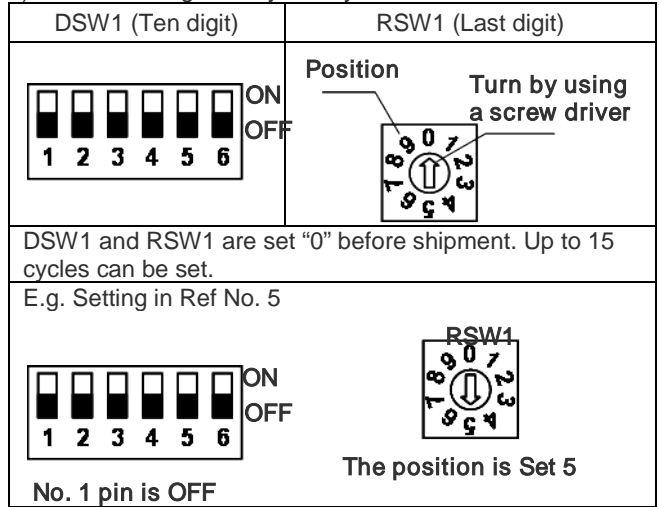

- 4) Set the unit No. by RSW2 and DSW2

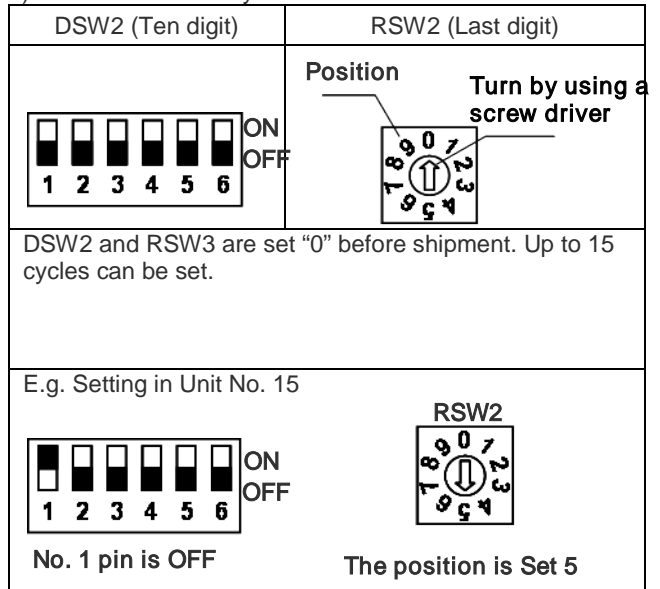

- 5) Slave unit.

In case of setting various RAC adaptors in the same refrigerant cycle, set the RAC adaptor with smallest Unit# as a master unit. In case of setting only one RAC adaptor in a refrigerant system, this adaptor should be a master unit. Set this procedure by DSW3.

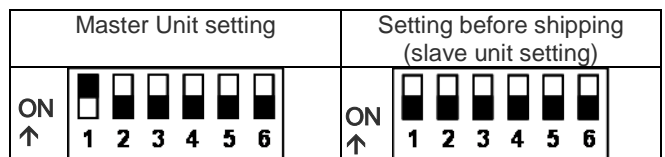

●: Master Unit setting

○: Setting before Shipping (Slave Unit setting)

		Indoor Unit#								
		0	1	2	3	4	5	6	7	
Refrigerant Unit#	0	●	○	○	○	○				
	1			●	○	○				
	2				●	○	○	○	○	
	3		●							
	4									

CAUTION:

– DO NOT set various main adaptors in the same refrigerant cycle.

- 6) Procedure when applying 200V voltage to H-LINK wiring incorrectly.

In case of applying 200V voltage to H-LINK wiring incorrectly, the fuse installed in a transmission circuit on PCB will blow out. In this case, reconnect the wiring correctly and turn ON No. 2 pin of DSW4 on PCB. The transmission circuit can be recovered. (If applying this error again, the transmission circuit can not be recovered)

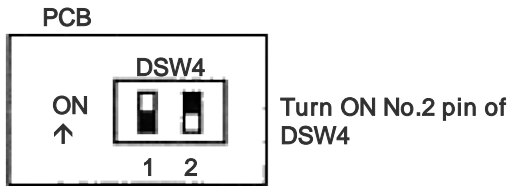

- 7) Terminating resistance is set in whole H-LINK system.
 - a) If H-LINK connecting devices like package air-conditioner are connected besides the RAC Adaptor, set the terminating resistance by those connecting devices. The terminating resistance should be set ON in only one position in whole H-LINK system.
 - b) In case that H-LINK is connected only by the RAC adaptor, set the terminating resistance by the RAC adaptor. The terminating resistance should be set ON in only one position in whole H-LINK system.

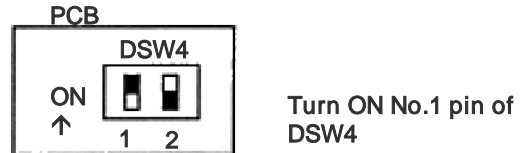

10.2.5. TEST RUN

Test run should be performed in the following after finishing the installation, wiring and setting. Refer to the installation manuals enclosed with the control system equipment.

- 1) Confirmation of RAC Adaptor Connection

Confirm if the RAC adaptor connection is recognized in the control system equipments. In case that it is not confirmed, check the transmission cable, refrigerant cycle #, indoor unit #, terminal resistance setting etc.
- 2) Registration

Confirm if the RAC adaptor connection is recognized.
- 3) Confirmation of RUN/STOP Operation.

Confirm if the room air-conditioner operate correctly by RUN/STOP from the central control system equipments. Check also if the room air-conditioner operation changes correctly by each setting.

10.3. DRY CONTACT (SPX-WDC3) APPLICATION (USING DIP SWITCH)

The dry contact system enables the operation of the air conditioner indoor unit to be controlled by using external dry contacts (with non voltage) such as card-key controller or window for facilities such as hotels.

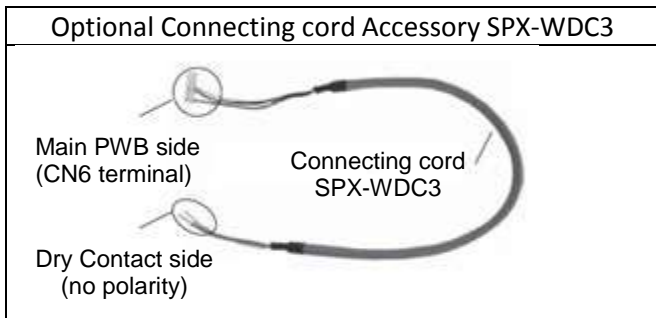

Note:

- 1) DRY CONTACT function is "Enable" by set pin No. 2 of the DIP SWITCH (DSW1) to ON position.
- 2) Select the proper setting for DRY CONTACT LOGIC INPUT pin No. 3 on DIP SWITCH (DSW1)
 - i) Set to OFF position (Hi Input) if the type of Dry Contact switch to be used (for the CARD KEY UNIT or Window) is of contact type a (Normally Open Type) as shown in below diagram.
 - ii) Set to ON position (Lo Input) if the type of Dry contact switch to be used (for the CARD KEY UNIT or Window) is of contact type b (Normally Close Type) as shown in below diagram.

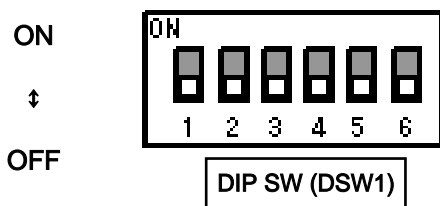

Pin No.	Function	Switch Position / Setting			
		OFF	Disable	ON	Enable
2	DRY CONTACT function	OFF	Disable	ON	Enable
3	DRY CONTACT Input Logic	OFF	HI Input Active	ON	LO Input Active

- Please decide the type of dry contact you will be using and set the position of the DIP Switch No. 2 and 3 accordingly

[1] CHECK DRY CONTACT OF CARD KEY UNIT

	AIR CONDITIONER Standby	AIR CONDITIONER Operating
	CARD KEY (Door Switch)	REMOVE
Contact type a	OPEN 	CLOSE
Contact type b	CLOSE 	OPEN

[2] SET THE POSITION OF DIP SWITCH

POSITION CONDITION OF DIP SWITCH	
<p>INITIAL CONDITION (CARD KEY NO USE)</p> <p>No.2 : OFF No.3 : OFF</p>	
<p>HI Input Active</p> <p>No.2 : ON No.3 : OFF</p>	
<p>LO Input Active</p> <p>No.2 : ON No.3 : ON</p>	

After all connection has been done as below diagram, ON the breaker and push ON button of wireless remote controller or wired remote controller to operate the air conditioner unit.

- When the CARD KEY is in insert condition, the air conditioner operation is allowable by remote controller.
- When the dry contact switch on the Card Key Unit is open (refer to diagram below for contact type a), the unit stops to operate (it takes 10 seconds to stop the unit operation after the dry contact switch on the card key turns off) and vice versa.
- When the card key is removed from the Card Key Unit, the wireless remote controller cannot be used.
- When the card key is removed from the Card Key Unit, the wired remote controller LCD display is activated; however it has no control over the unit.
- The suitable accessory Connecting Cord (accessory code#: SPX-WDC3) need to be used to connect the Card Key Unit's dry contact switch to the connector on the control board of the indoor unit

Example of wiring connection to Card Key Unit will be as below (reference only)

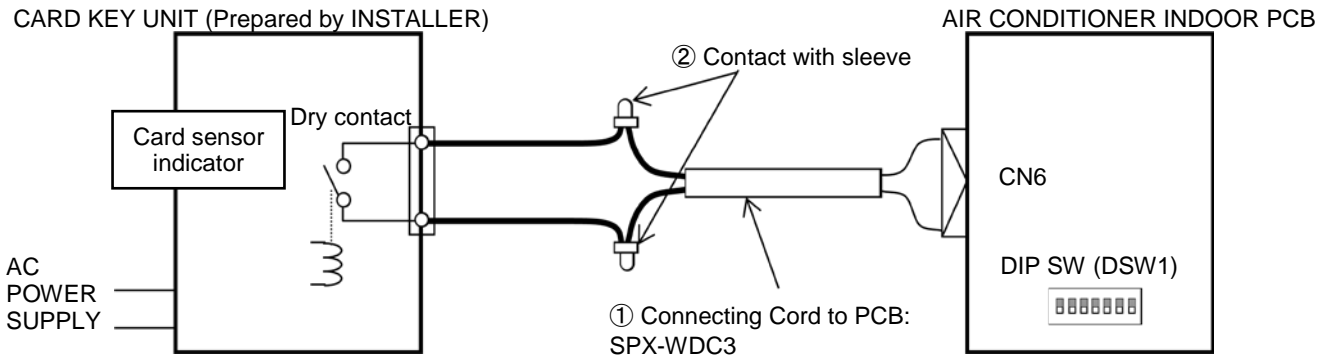

• CONNECTION EXAMPLE

i. Pin No. 3 of DIP SWITCH is set to OFF position (HI Input Active) for Dry Contact Type a

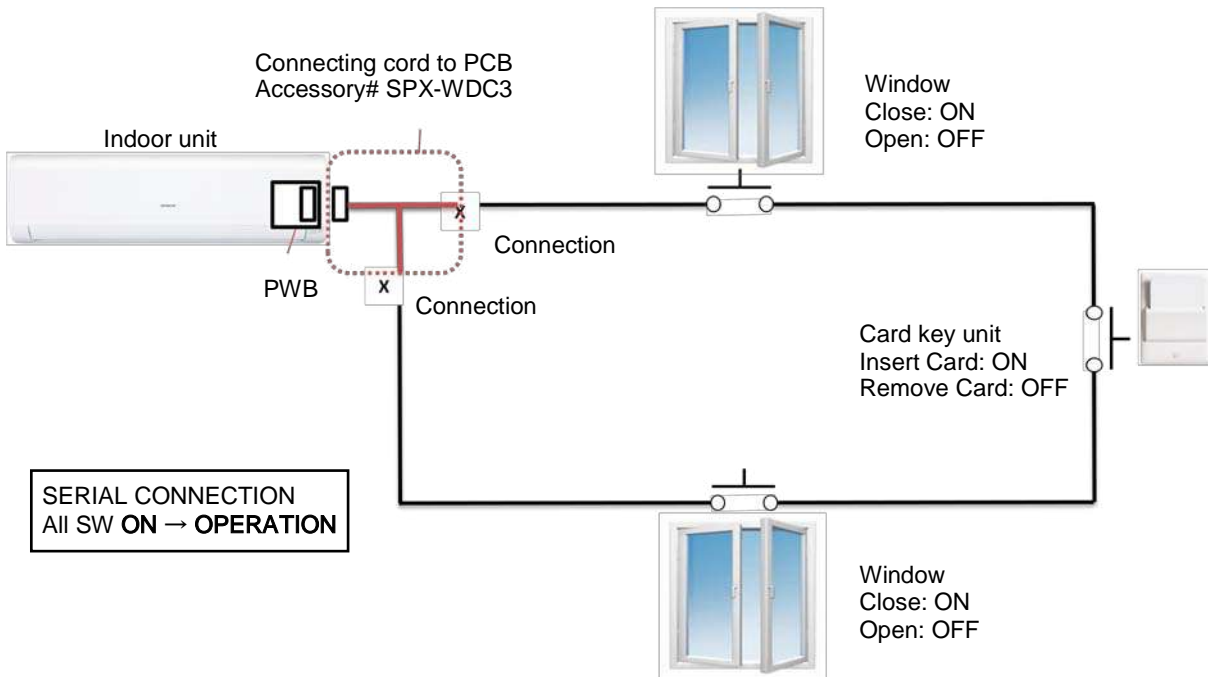

ii. Pin No. 3 of DIP SWITCH is set to ON position (LO Input Active) for Dry Contact Type b

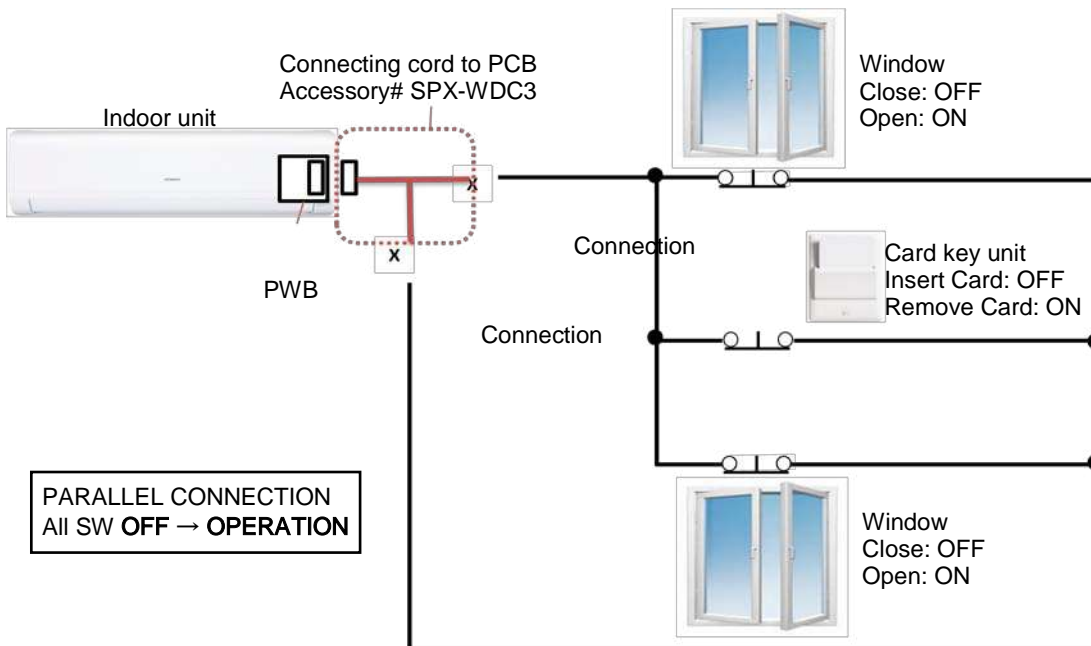

Please refer to the actual manual supplied with the optional connecting cords SPX-WDC3 for more details.

10.4. DISTRIBUTOR – SPX-DST1

The optional distributor is to be used together with the wired remote controller when there is a need to centralize the control of multiple indoor units using only a single wired remote controller.

A single distributor could be connected further to 3 separate distributors so that up to 13 units of indoor could be controlled by a single wired remote controller.

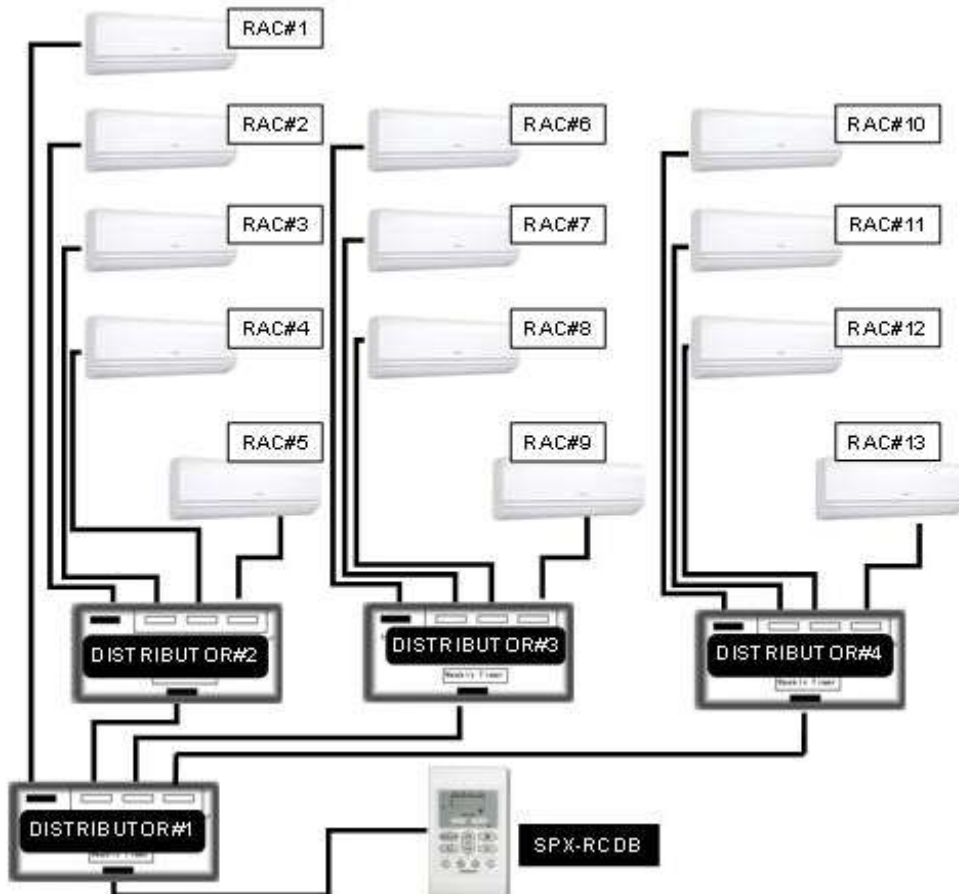
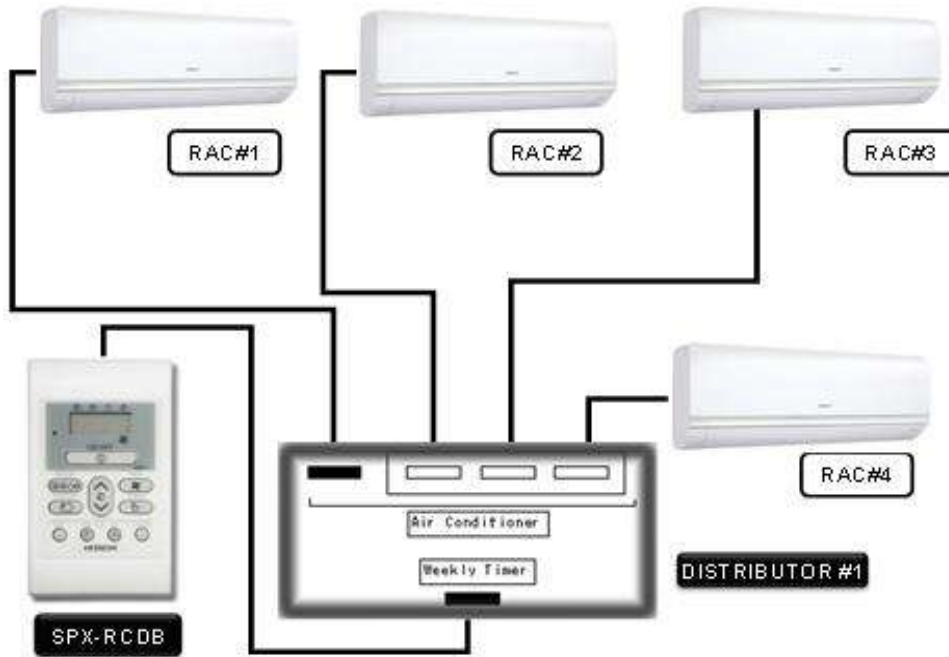

Gas sensor installation instruction manual (Option parts No: SPX-RAFGLS)

1. Remove the front cover (Turn off circuit breaker first)

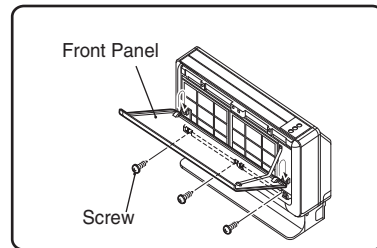
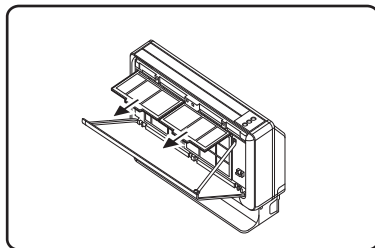
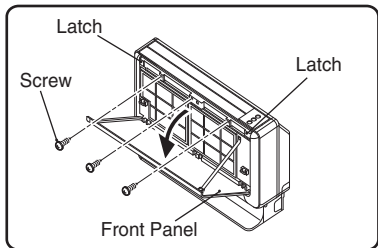

a. Push the latch at both sides to open the front panel.
Pull out the filter and remove 3 screws.

b. Lift up the front panel and latch the claws firmly at the lower part of rear of the front panel.
Then remove 3 screws.

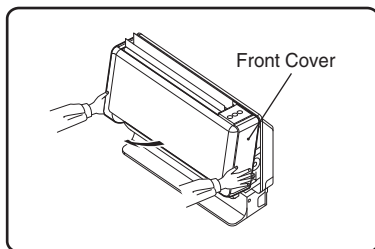
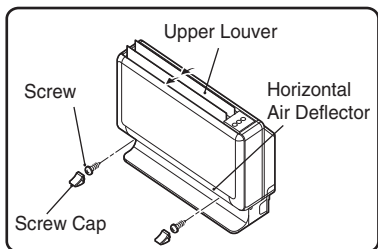

c. Take off 2 screw caps at the lower part of the horizontal air deflector and remove 2 screws. Then leave the upper louver in open position.

d. Hold both sides of the lower part of front cover and pull up towards an oblique direction.

2. Install the gas sensor

Fix a screw ③ and confirm assembly with support is reliable.

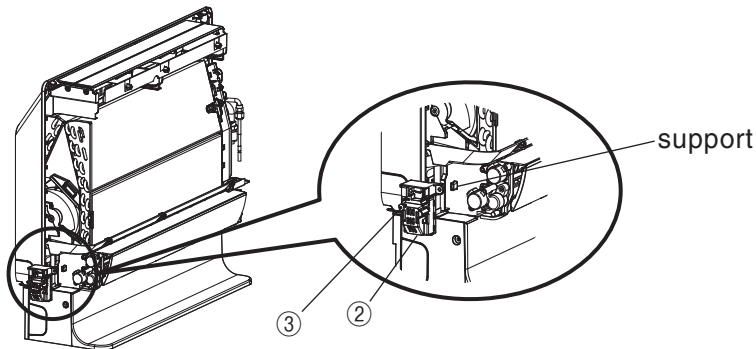

Parts list in package

No	component
①	Instruction manual
②	Gas sensor assembly
③	Fixing screw
④	Fixing sheet x 4
⑤	Caution label

3. Gas sensor wiring and connect to IDU PCB

a. Remove the PCB cover then set the DSW2 PIN1 to ON and connect cable to CN33 of PCB.

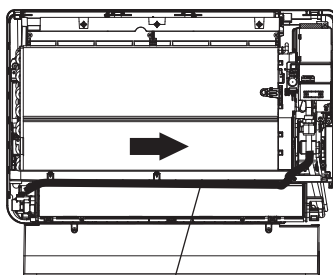

Wiring direction

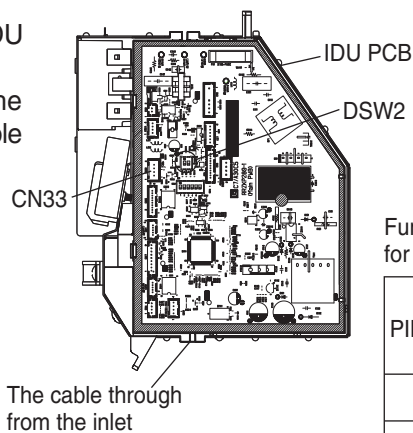

The cable through from the inlet

Image of DSW2 after set

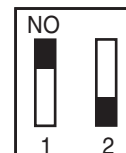

Function description please refer as follows for DSW2 setting.

PIN NO.	Function	Switch position	
		ON	OFF
1	Gas sensor	Valid	Invalid
2	Detection time for gas leakage	40s	20s

b. Fixing position details for sensor cable(4points)

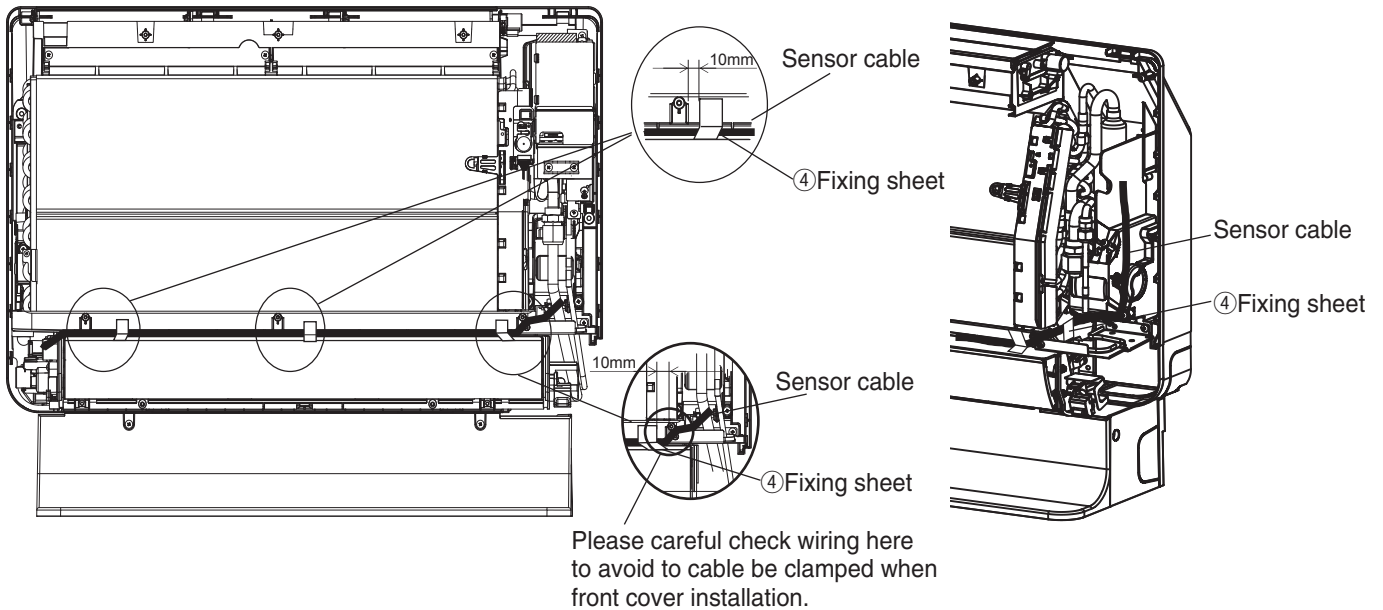

	Please confirm fixing sheet isn't put it into drain pan to avoid to drain water falling down.
--	---

4. Installation confirmation (Turn on the circuit breaker first)

The green led lights during connection was normal, If there are abnormal indications, Please refer as follows.

TIMER lamp 8 times blinks	Please check the DIP-switch set to ON. And the status of the green led.	
Green led lights off	Please check the sensor cable whether has connection issues or break.	
Green led blinks	Please replace this gas sensor because of fault.	

5. Reattach the front cover to indoor unit (Turn off the circuit breaker first)

6. Fixing caution label to indoor unit for user attention

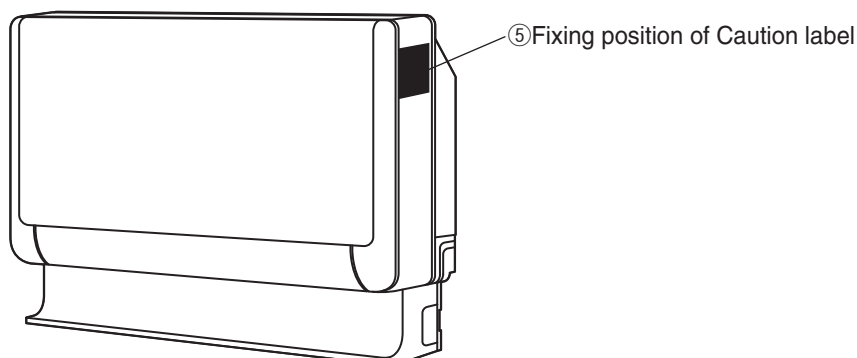

Remarks: 1.Refrigerant lamp alarm please refer the operation manual.
2.Service life of the gas sensor is 5 years.

HITACHI

TC_ERP-FXE00-07/15